

Exam.	Back		
Level	BE	Full Marks	80
Programme	BEL, BEX, BCT	Pass Marks	32
Year / Part	II / I	Time	3 hrs.

Subject: - Electric Circuit Theory (EE 501)

- ✓ Candidates are required to give their answers in their own words as far as practicable.
- ✓ Attempt All questions.
- ✓ The figures in the margin indicate Full Marks.
- ✓ Semi log paper will be provided.
- ✓ Assume suitable data if necessary.

1. a) In the circuit shown in figure below, find the value of "v", using node voltage method. [8]

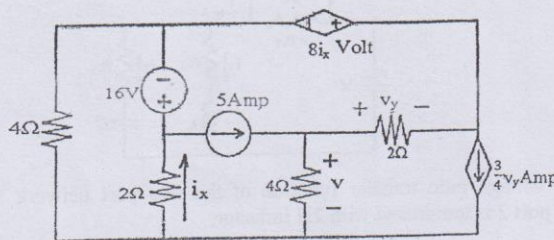

- b) In the given network of figure below, inductor L_1 is energized and the switch K is closed at $t = 0$. When each element has following values.

$$R_1 = 10k\Omega, R_2 = 5k\Omega, L_1 = 2mH, L_2 = 6mH, \text{ solve for } i_1, i_2, \frac{di_1}{dt}, \frac{di_2}{dt},$$

$$\frac{d^2 i_1}{dt^2}, \frac{d^2 i_2}{dt^2} \text{ at } t = 0^+.$$

[8]

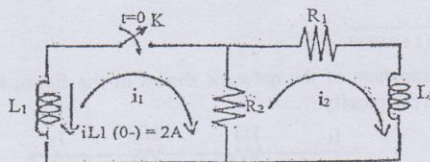

2. a) Solve for $i(t)$ in circuit as shown in figure below in which 3F capacitor is initially charged to 20 volts, 6F capacitor to 10 volts and the switch is closed at $t=0$. Use classical method. [8]

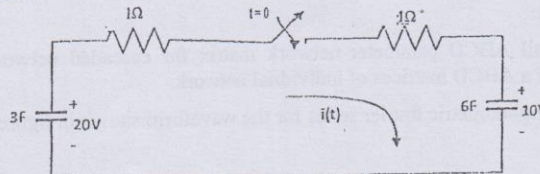

- b) An exponential current $i(t) = 20 e^{-5t}$ Amp is suddenly applied at time $t = 0$ to a parallel RLC circuit comprising of resistor $R = 1/10\Omega$, inductor $L = 10mH$ and capacitor $C = 2.5\mu F$. Obtain the complete particular solution for voltage $v(t)$ across the network, by classical method. Assume zero initial current through inductor and zero initial charge across the capacitor before application of the current. [8]

3. a) The circuit below is in the steady state with the switch S closed. The switch is opened at $t = 0$. Determine the current through capacitor for $t > 0$ using Laplace's Transform method. [8]

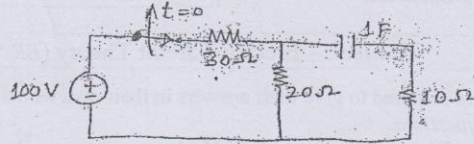

- b) In the network shown below, a steady state is reached with the switch K open with $V = 100V$, $R_1 = 10\Omega$, $R_2 = 20\Omega$, $R_3 = 20\Omega$, $L = 1H$, and $C = 1\mu F$. At time $t = 0$, the switch is closed. i) Write integrodifferential equation for the network after switch is closed. ii) Evaluate the currents i_1 and i_2 , using Laplace transform, for $t > 0$. [8]

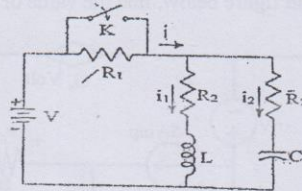

4. a) Find the voltage ratio transfer function of the two port network shown in figure below, if port 2 is terminated with 2H inductor. [8]

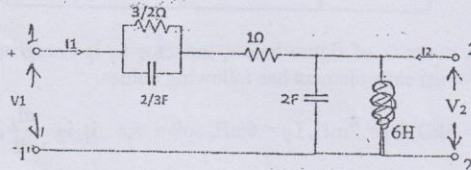

- b) Define frequency response and explain how frequency response of a system can be obtained. Draw the Bode plot of following transfer function. [8]

$$G(s) = \frac{1}{s(1+0.5s)(1+0.05s)}$$

5. a) Find y and g parameters of the network shown in the figure below. Also check its symmetricity and reciprocity. [6]

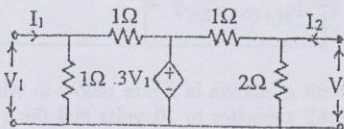

- b) Show that:

The overall ABCD parameter network matrix for cascaded network is the matrix product of a ABCD matrices of individual network. [4]

- c) Find the trigonometric fourier series for the waveform shown in figure below. [6]

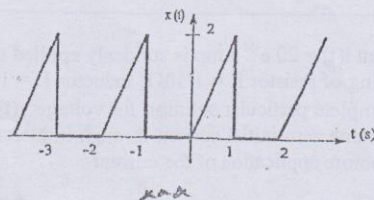

Exam.	Back		
Level	BE	Full Marks	80
Programme	BEL, BEX, BCT	Pass Marks	32
Year / Part	II / 1	Time	3 hrs.

Subject: - Electric Circuit Theory (EE 501)

- ✓ Candidates are required to give their answers in their own words as far as practicable.
- ✓ Attempt All questions.
- ✓ The figures in the margin indicate Full Marks.
- ✓ Assume suitable data if necessary.

1. a) Using nodal analysis, determine the current through 4Ω resistor connected between terminals A and B for the network of following figure. [8]

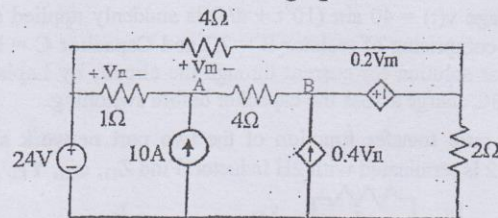

- b) In the circuit shown below, the inductor is suddenly disconnected from the dc supply. Find (i) the initial rate of change of current just after switching (ii) initial voltage across 20Ω (iii) the voltage across the switch at the instant of separation of contacts. [8]

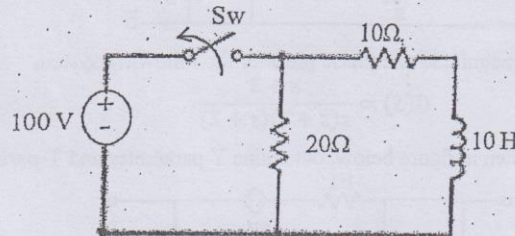

2. a) In a series R-L circuit with $R = 1\Omega$ and $L = 1H$, the voltage source follows the law $v(t) = Ve^{-\alpha t}$, where α is a constant. The switch is closed at $t = 0$. [8]

- (i) Solve for the current assuming that $\alpha \neq \frac{R}{L}$ and
- (ii) Solve for the current when $\alpha = \frac{R}{L}$ using classical method.

- b) In the network shown, the switch is closed at $t = 0$, with the network previously unenergised. For the element values shown on the diagram, find $i_1(t)$ and $i_2(t)$ by classical method for $t > 0$. [8]

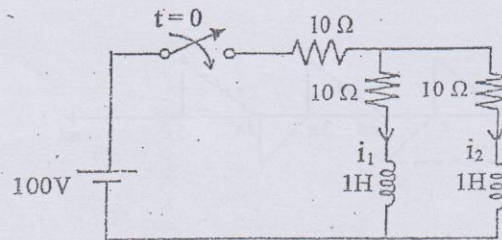

3. a) In the circuit shown in figure below, a switch S is in the position 1 for a long time and moved to position 2 at $t = 0$. Find the voltage across the capacitor for $t > 0$. Use Laplace Transformation method. [8]

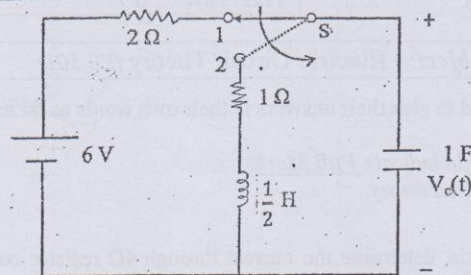

- b) A sinusoidal voltage $v(t) = 40 \sin(10^6 t + \pi/4)$ is suddenly applied at time $t = 0$ to series RC circuit comprising of resistor $R = 2\Omega$ and Capacitor $C = 1/4$ F. Obtain the complete particular solution for current through the circuit, by Laplace's Transform method. Assume $3C$ charge across the capacitor before switching. [8]
4. a) Find the voltage ratio transfer function of the two port network shown in figure below. If the port 2 is terminated with $2H$ inductor. Find Z_{11} , α_{21} , Y_{12} . [8]

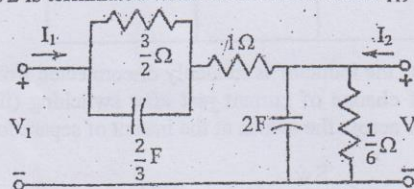

- b) Draw the bode log-magnitude and phase plots for the following system [8]

$$G(S) = \frac{s+3}{s(s+1)(s+2)}$$

5. a) For the network shown in figure below, determine Y parameter and T-parameter. [8]

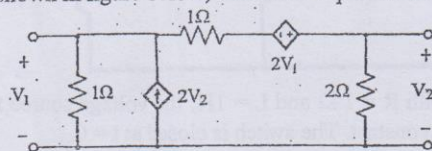

- b) Derive the condition for reciprocity in term of inverse transmission parameter in a TPN. [4]
- c) Find the trigonometric Fourier Series of the waveform shown in figure below. Also plot the line spectra. [4]

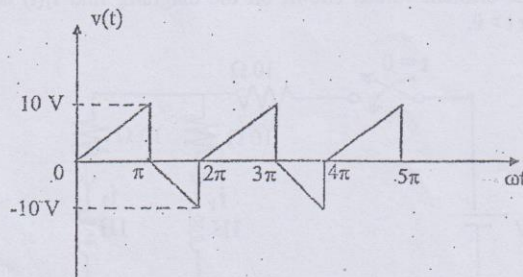

TRIBHUVAN UNIVERSITY
INSTITUTE OF ENGINEERING
Examination Control Division
2078 Bhadra

Exam.	Regular		
Level	BE	Full Marks	80
Programme	BEL, BEX, BCT	Pass Marks	32
Year / Part	II / I	Time	3 hrs.

Subject: - Electric Circuit Theory (EE 501)

- ✓ Candidates are required to give their answers in their own words as far as practicable.
- ✓ Attempt All questions.
- ✓ The figures in the margin indicate Full Marks.
- ✓ Semi-log graph paper is to be provided.
- ✓ Assume suitable data if necessary.

1. a) Explain the phenomenon of resonance in a practical parallel resonant circuit and hence obtain the expression for resonant frequency. How does it differ from an ideal circuit? [8]
- b) At $t = 0$ switch changes its position from a to b. Find current and voltage of each element at $t = 0^+$. Also find the initial value of first order derivatives of inductor voltage and inductor current. [8]

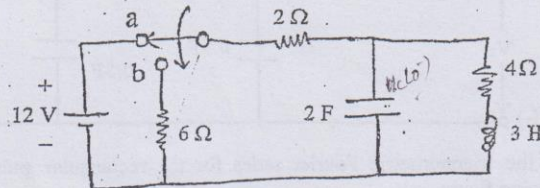

2. a) In the circuit shown in figure below, if the switch is closed at $t = 0$, find the time when the current from the battery reaches to 500 mA. Use classical method. [8]

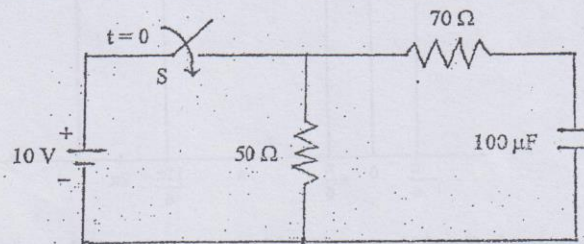

- b) In the circuit shown in figure below, capacitor C has an initial voltage $V_c = 10$ volts and at the same instant, current through inductor L is zero. The switch S is closed at time $t = 0$. Find out the expression for the voltage $v(t)$ across the inductor L using classical method. [8]

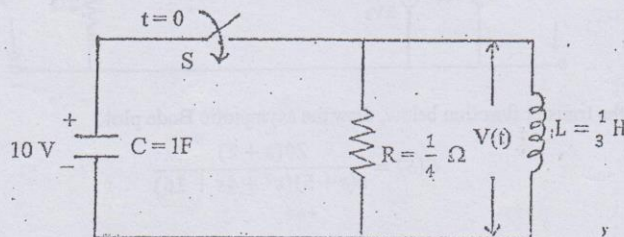

3. a) Using Laplace transform method find the current through the inductor in the network shown in figure below. [8]

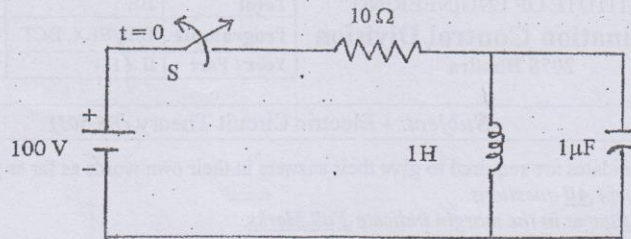

- b) A RLC series circuit with $R = 4\Omega$, $L = 1H$ and $C = 1/3 F$ is excited by an exponential source of $20e^{-3t}$. Find the expression of the current in the circuit for $t > 0$ using Laplace Transform. [8]
4. a) For the given two port network, determine the driving point impedance and voltage ratio transfer function. [8]

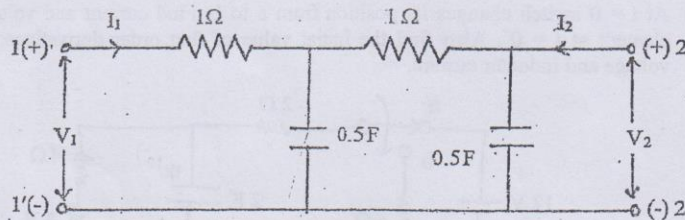

- b) Find the trigonometric Fourier series for the rectangular pulse as shown in the following figure. [8]

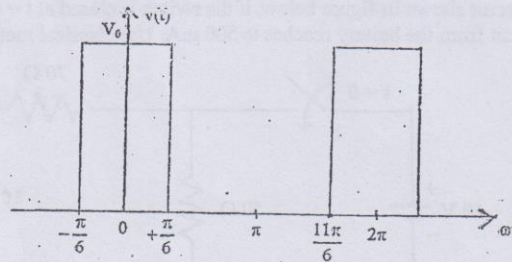

5. a) Determine the Z and Y parameters of the two port network shown below. [8]

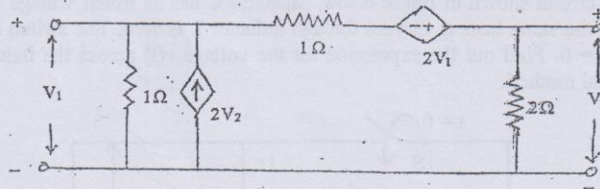

- b) For the transfer function below, draw the asymptotic Bode plot. [8]

$$G(S) = \frac{20(s+2)}{s(s+5)(s^2+4s+16)}$$

Exam.	Regular		
Level	BE	Full Marks	80
Programme	BEL, BEX, BCT	Pass Marks	32
Year / Part	II / I	Time	3 hrs.

Subject: - Electric Circuit Theory (EE 501)

- ✓ Candidates are required to give their answers in their own words as far as practicable.
- ✓ Attempt All questions.
- ✓ The figures in the margin indicate Full Marks.
- ✓ Semi-log graph paper is to be provided.
- ✓ Assume suitable data if necessary.

1. a) Explain the phenomenon of resonance in RLC parallel circuit. Also derive the expression for resonance frequency and draw the wave form of instantaneous voltage and current at resonance. [8]
- b) In the circuit shown below, the switch has been closed for a long time and at $t = 0$ it is opened, determine (i) $i(0^+)$ (ii) $v(0^+)$ (iii) $v_L(0^+)$ and (iv) I and v at $t = 20\mu s$. [8]

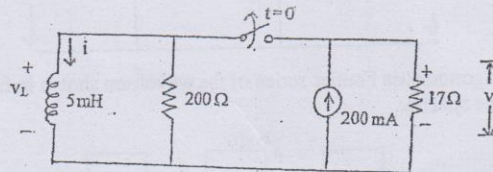

2. a) In the network given below, the switch K is open and the network reaches a steady state. At $t = 0$, switch K is closed. Find the current in the inductor for $t > 0$ using classical method. [8]

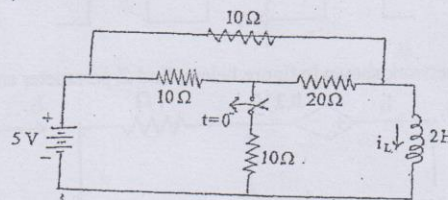

- b) Use Laplace transform approach to find the voltage across the capacitor $V_C(t)$ for $t > 0$ when the switch is moved to position 'b' at $t = 0$ which was in position 'a' for a long time prior to switching. [8]

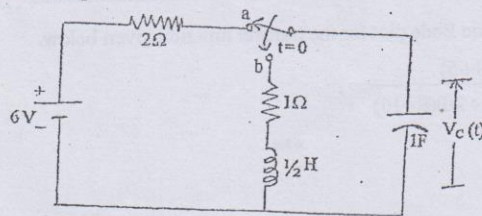

3. a) An exponential current $i(t) = 2e^{-3t}$ is applied at time $t = 0$ to a parallel R-C circuit shown below. Comprising resistor $R = \frac{1}{2}\Omega$ and capacitor $C = 1F$. Obtain complete solution for $v(t)$. Assume $V_C = 0$ before the application of current. Use Laplace transform method. [8]

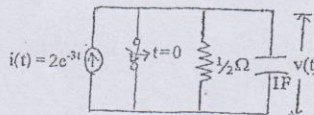

- b) In the circuit shown in figure below, steady state is reached with switch S open. Switch S is closed at $t = 0$. Determine current through inductor $i(t)$ and voltage across the capacitor $v(t)$ for $t > 0$ using Laplace transform method. [8]

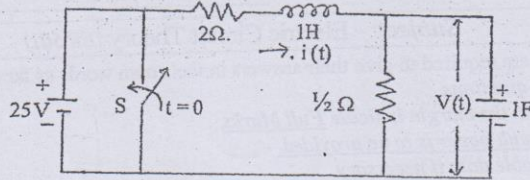

4. a) For the following network determine the voltage ratio transfer function. If this network is terminated at port 2 with a 2Ω resistor, find for this terminated network $\alpha_{21}(S)$ and $V_{21}(S)$. [8]

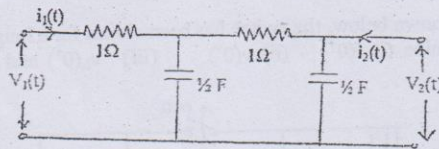

- b) Obtain the trigonometric Fourier-series of the waveform shown in figure below and sketch the line spectra. [8]

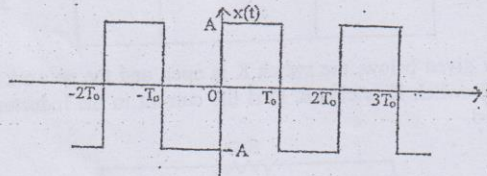

5. a) For the two port network shown in figure below, find Z-parameter and T-parameter. [8]

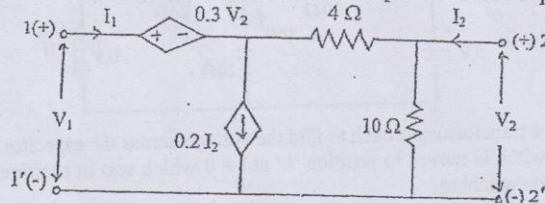

- b) Draw the asymptotic Bode plot for the transfer function given below. [8]

$$G(S) = \frac{2(S+5)}{S(S^2 + 21S + 20)(S+10)}$$

Exam.	Back		
Level	BE	Full Marks	80
Programme	BEL, BEX, BCT	Pass Marks	32
Year / Part	II / I	Time	3 hrs.

Subject: - Electric Circuit Theory (EE 501)

- ✓ Candidates are required to give their answers in their own words as far as practicable.
- ✓ Attempt *All* questions.
- ✓ The figures in the margin indicate *Full Marks*.
- ✓ *Semi log graph will be provided.*
- ✓ Assume suitable data if necessary.

1. a) A $50 \mu\text{F}$ capacitor, when connected in series with a coil having 40Ω resistance, resonates at 1000 Hz . Find the inductance of the coil. Also obtain the circuit current if the applied voltage is 100V . Also calculate the voltage across the capacitor and the coil at resonance. [8]
- b) In the circuit shown in figure, switch is closed at $t=0$ with zero capacitor voltage and zero inductor current, find the following. [8]
- i) v_1 and v_2 at $t=0+$
 - ii) dv_1/dt and dv_2/dt at $t=0+$
 - iii) d^2v_2/dt^2 at $t=0+$

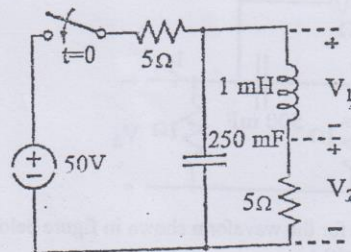

2. a) The circuit shown in figure is in the steady state with the switch S closed. The switch is opened at $t=0$. Determine current and voltage of all elements for $t>0$ using classical method. [8]

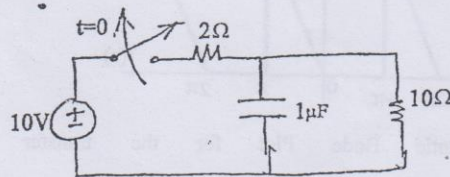

- b) Using Classical method, find the expression for current and voltage of capacitor for $t>0$ in the circuit shown below. [8]

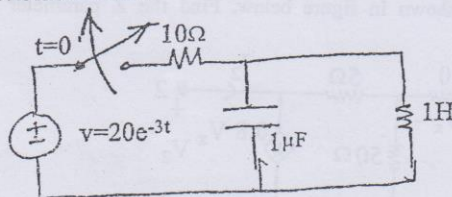

3. a) Keeping the switch at position 'a' for a long time, if the switch is moved to position 'b' at $t = 0$ in the circuit shown in figure below, find expressions for current through and voltage across capacitor using Laplace transform method. [8]

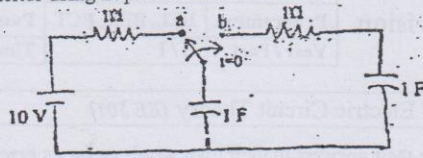

- b) In the given network of figure below, both the energy storing elements are initially reached to steady state, before application of current source. The switch K is closed at $t=0$. Find complete expression for voltage $v(t)$ across the network, for $t>0$, using Laplace transformation. [8]

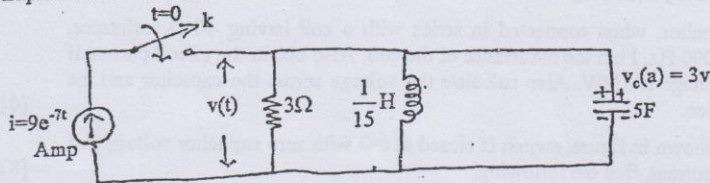

4. a) Find the input point driving impedance, transfer impedance, and voltage ratio transfer function for the circuit shown in following figure. [8]

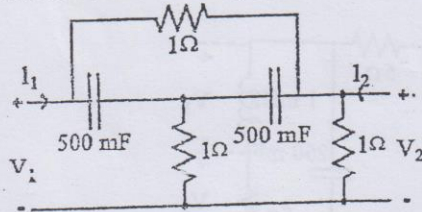

- b) Find the trigonometric fourier series for the waveform shown in figure below. [8]

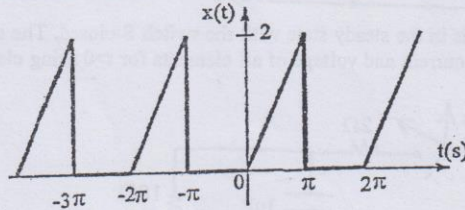

5. a) Draw the asymptotic Bode Plot for the transfer function [8]
- $$H(s) = \frac{(s+5)}{s(s^2+21s+20)(s^2+2s+100)}$$

- b) For the two port network shown in figure below. Find the Z parameter and T parameter. [8]

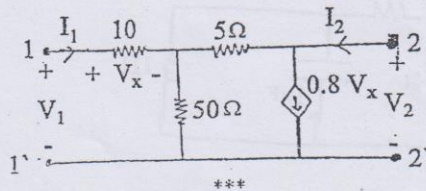

Exam.	Regular / Back		
Level	BE	Full Marks	80
Programme	BEL, BEX, BCT	Pass Marks	32
Year / Part	II / I	Time	3 hrs.

Subject: - Electric Circuit Theory (EE 501)

- ✓ Candidates are required to give their answers in their own words as far as practicable.
- ✓ Attempt All questions.
- ✓ The figures in the margin indicate Full Marks.
- ✓ Semi log graph will be provided.
- ✓ Assume suitable data if necessary.

1. a) Discuss about resonance in a circuit consisting of a practical coil in parallel with a capacitor. Also derive an expression for impedance and current at resonating frequency. [8]
- b) In the given network of figure below, both the energy storing elements are initially relaxed i.e. no current is flowing through the inductor and no charge is accumulated across the capacitor before application of voltage. The switch K is closed at $t=0$. Find the values of i_1 , i_2 , $\frac{di_1}{dt}$, $\frac{di_2}{dt}$, $\frac{d^2i_1}{dt^2}$, $\frac{d^2i_2}{dt^2}$ at $t=0^+$. [8]

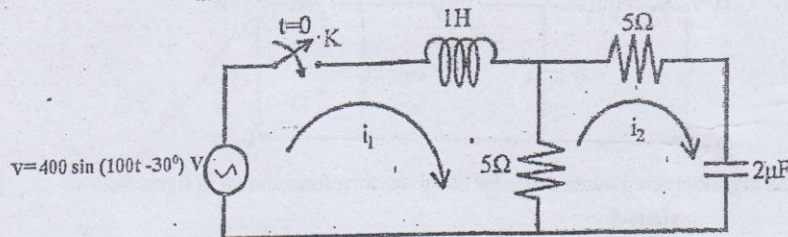

2. a) Using classical method, find the expression for the current supplied by the source in the network shown in figure. Also find the time taken by the source current to reach 25 mA. [8]

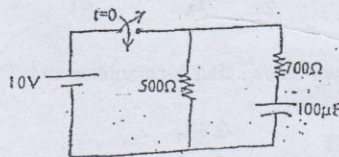

- b) Using classical method, find the expression for the current and voltage of inductor and capacitor respectively for $t > 0$ from the circuit shown in following figure. [8]

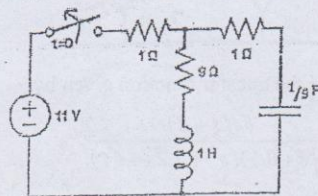

3. a) In the series R-L-C circuit shown in figure, there is no initial charge on the capacitor. If the switch S is closed at $t=0$, determine expression of current and voltage for all elements for $t>0$. [8]

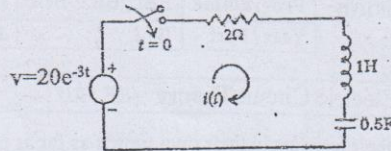

- b) Using Laplace transform method, find the loop current i_1 and i_2 for $t>0$ in the figure shown below. [8]

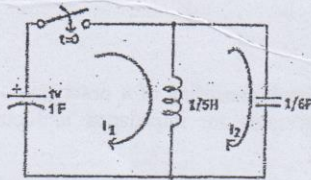

4. a) For the given two port network, determine the driving point impedance. If this network is terminated at port 2 with 1F capacitor, find the following network function for this terminated network, (i) $Z_{21}(s)$ (ii) $Y_{21}(s)$ (iii) $\alpha_{21}(s)$ [8]

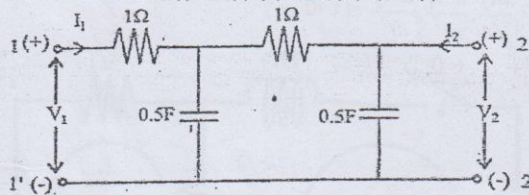

- b) Find the trigonometric Fourier series for the given waveform shown in figure below. [8]

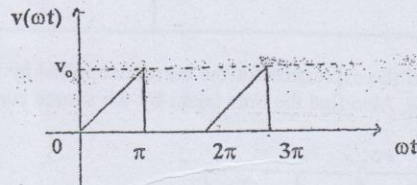

5. a) For the two port network shown below, find h-parameter and T' parameter. Also Check for reciprocity of network. [8]

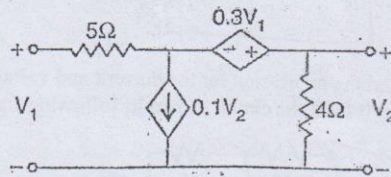

- b) Draw the asymptotic bode plot for the transfer function given by: [8]

$$G(s) = \frac{64(s+2)}{s(s+0.5)(s^2+3.2s+64)}$$

Exam.	Back		
Level	BE	Full Marks	80
Programme	BEL, BEX, BCT	Pass Marks	32
Year / Part	II / I	Time	3 hrs.

Subject: - Electric Circuit Theory (EE501)

- ✓ Candidates are required to give their answers in their own words as far as practicable.
- ✓ Attempt All questions.
- ✓ The figures in the margin indicate Full Marks.
- ✓ Semi log paper should be provided.
- ✓ Assume suitable data if necessary.

1. a) What do you mean by resonance in RLC series circuit? Define half power frequencies and bandwidth in RLC series circuit and also obtain an expression for them. [8]

b) In the given network, the capacitor C_1 is charged to voltage V_0 and switch K is closed at $t = 0$. When $R_1 = 2M\Omega$, $V_0 = 1000V$, $R_2 = 1 M\Omega$, $C_1 = 10\mu F$ and $C_2 = 20\mu F$, solve for $i_1, i_2, \frac{di_2}{dt}, \frac{d^2i_2}{dt^2}$ at $t = 0^+$. [8]

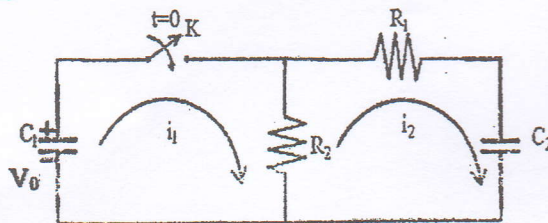

2. a) In the network shown, the switch is closed at $t = 0$, with the network previously unenergised. For the element values shown on the diagram, find $i_1(t)$ and $i_2(t)$, by classical method for $t > 0$. [8]

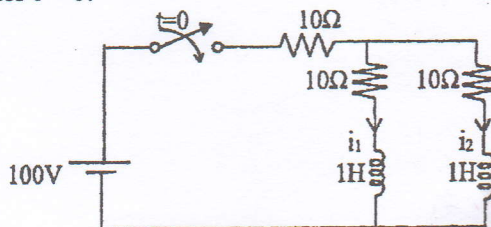

b) Find the time expression for current for $t > 0$ in RLC series circuit with $R = 10 \text{ ohm}$, $L = 1H$ and $C = \frac{1}{9}F$, if the circuit is supplied by $v = 10\sin t$ at $t = 0$. Assume that capacitor and inductor are initially de-energized. Use classical method. [8]

3. a) In the circuit shown in figure below, obtain an expression for voltage across the inductor if the switch is closed at $t = 0$ using Laplace Transform method. [8]

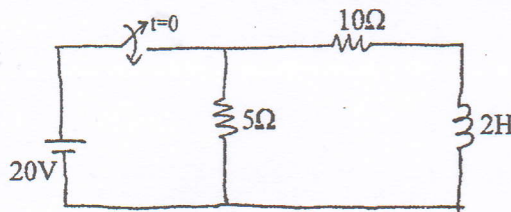

b) An exponential current $i(t) = 20e^{-4t}$ Amp is suddenly applied at time $t = 0$ to a parallel RLC circuit comprising of resistor $R = 1/10\Omega$, inductor $L = 10\text{mH}$ and capacitor $C = 2.5\mu\text{F}$. Obtain the complete particular solution for voltage $v(t)$ across the network, by Laplace transform method. Assume zero initial current through inductor and zero initial charge across the capacitor before application of the current.

[8]

4. a) Find the voltage ratio transfer function of the two port network shown in figure below, if the port 2 is terminated with 2H inductor.

[8]

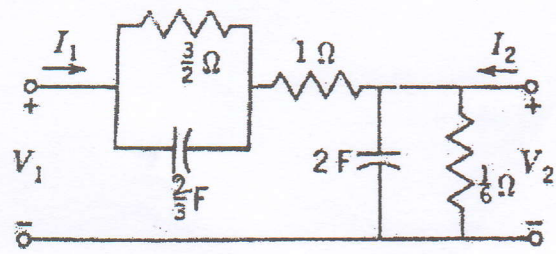

b) Sketch Bode Plot for the following transfer function.

[8]

$$H(s) = \frac{40(s+1)}{(2s^2 + 10s)(s^2 + 2s + 10)}$$

5. a) Find the Z-parameter and hence T' -parameter for the network shown in figure below also check if network is symmetrical.

[8]

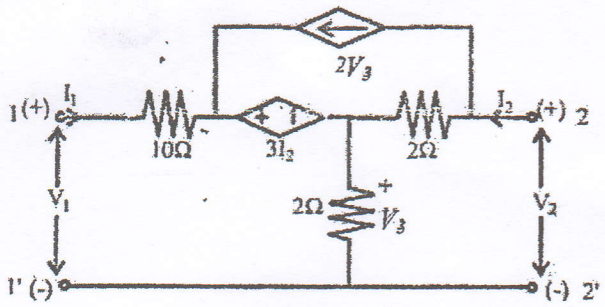

b) For the given waveform, find the trigonometric form of Fourier series and then plot its line spectrum.

[8]

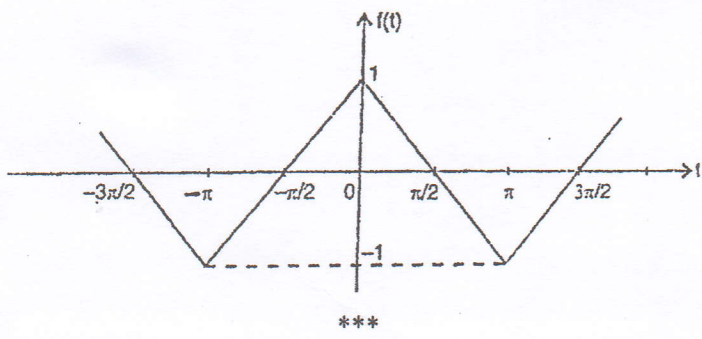

Exam.	Regular		
Level	BE	Full Marks	80
Programme	BEL, BEX, BCT	Pass Marks	32
Year / Part	II / I	Time	3 hrs.

Subject: - Electric Circuit Theory (EE501)

- ✓ Candidates are required to give their answers in their own words as far as practicable.
- ✓ Attempt **All** questions.
- ✓ The figures in the margin indicate **Full Marks**.
- ✓ **Semi log paper should be provided.**
- ✓ Assume suitable data if necessary.

1. a) Explain the phenomenon of resonance in RLC parallel circuit. Also derive the expression for resonance frequency and draw the wave form of instantaneous voltage and current at resonance. [8]
- b) Obtain the value of i_1 , i_2 , di_1/dt , di_2/dt , d^2i_1/dt^2 and d^2i_2/dt^2 at $t = 0^+$, if the switch is closed at $t = 0$ in the circuit shown in figure below. [8]

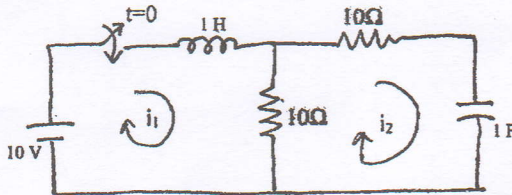

2. a) In the circuit shown in figure below, if the switch is closed at $t = 0$, find the time when the current from the battery reaches to 500mA. Use classical method. [8]

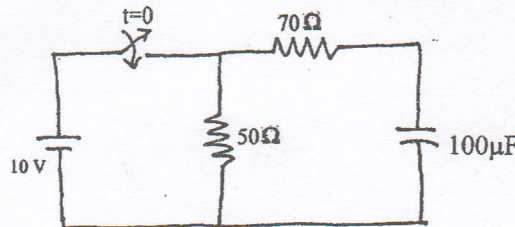

- b) Find the time expression for loop currents for $t > 0$ in the given circuit using classical method. [8]

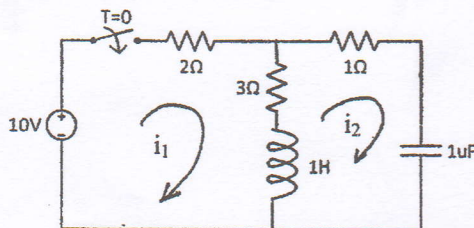

3. a) Keeping the switch at position 'a' for a long time, if the switch is moved to position 'b' at $t = 0$ in the circuit shown in figure below, find expressions for current through and voltage across capacitor using Laplace Transform method. [8]

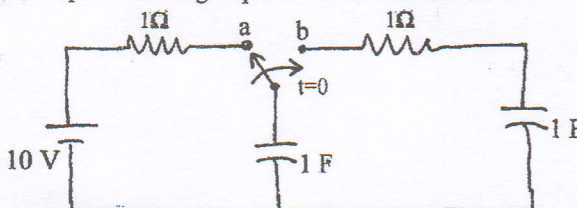

- b) In the network shown below, a steady state is reached with the switch K open with $V = 100V$, $R_1 = 10\Omega$, $R_2 = 20\Omega$, $R_3 = 20\Omega$, $L = 1H$, and $C = 1\mu F$. At time $t = 0$, the switch is closed. Evaluate the currents i_1 and i_2 , using Laplace transform, for $t > 0$. [8]

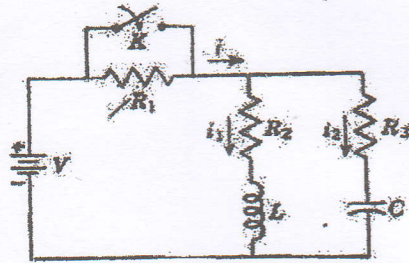

4. a) Find the forward voltage ratio transfer function $G_{21}(s)$ and forward transfer admittance $Y_{21}(s)$ in the following circuit. [8]

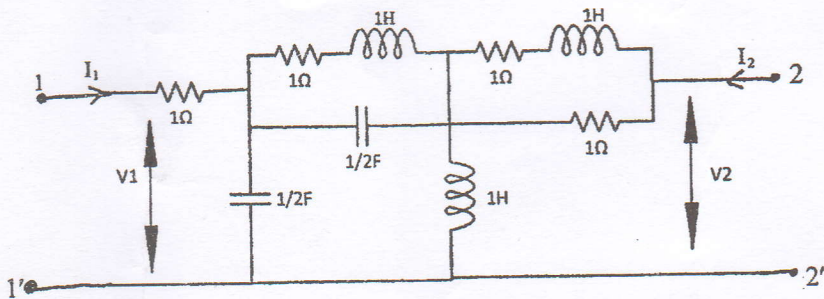

- b) Sketch the Bode Plot for the transfer function given by $H(S) = 64(S+2)/[S(S^2 + 0.5S)(S^2 + 3.2S + 64)]$ [8]
5. a) Find transmission and admittance parameter for the given TPN and check its reciprocity and symmetry. [8]

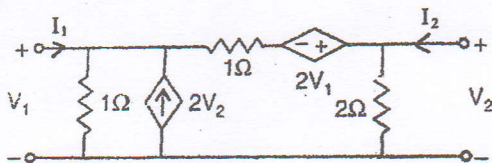

- b) Obtain trigonometric Fourier series of the waveform shown in figure below and sketch the line spectra. [8]

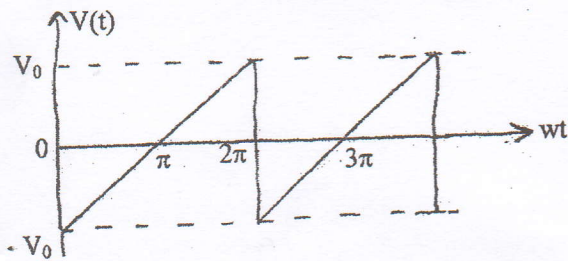

Exam.	Back	
Level	BE	Full Marks 80
Programme	BEL, BEX, BCT	Pass Marks 32
Year / Part	II / I	Time 3 hrs.

Subject: - Electric Circuit Theory (EE501)

Candidates are required to give their answers in their own words as far as practicable.

Attempt **All** questions.

The figures in the margin indicate **Full Marks**.

Semi log paper will be provided.

Assume suitable data if necessary.

a) Describe the resonance phenomenon in RLC series circuit. Define half power points and band width for a series RLC circuit and derive expression for them. [8]

b) In the given network of figure below, both the energy storing elements are initially relaxed i.e. no current is flowing through the inductor and no charge is accumulated across the capacitor before application of voltage. The switch K is closed at $t = 0$.

Find the values of $i_1, i_2, \frac{di_1}{dt}, \frac{di_2}{dt}, \frac{d^2i_1}{dt^2}, \frac{d^2i_2}{dt^2}$ at $t = 0^+$. [8]

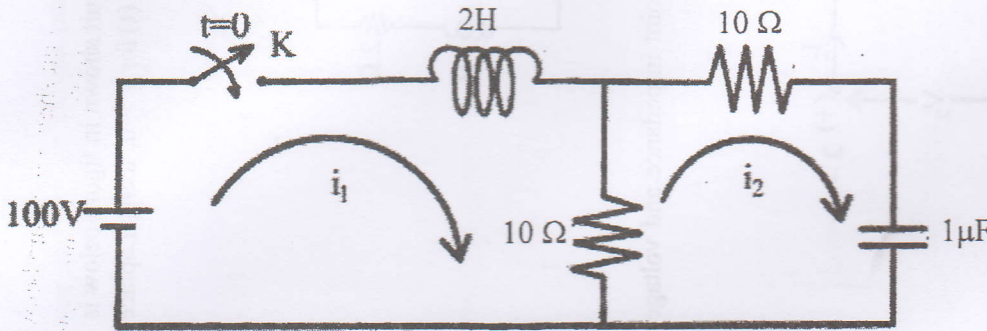

a) In the circuit shown in figure below, if the switch is closed at $t = 0$, find the expression for voltage across capacitor using classical method. [8]

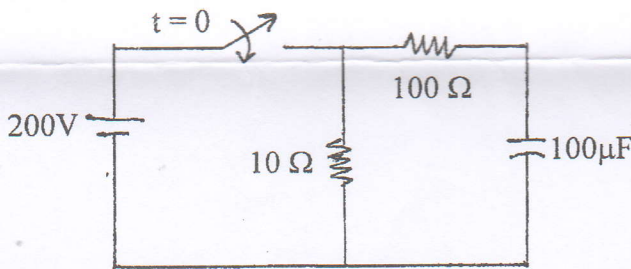

b) Keeping the switch closed for a long time, if the switch is opened at $t = 0$ in the circuit shown in figure below, find expression for voltage across capacitor using classical method of solution. [8]

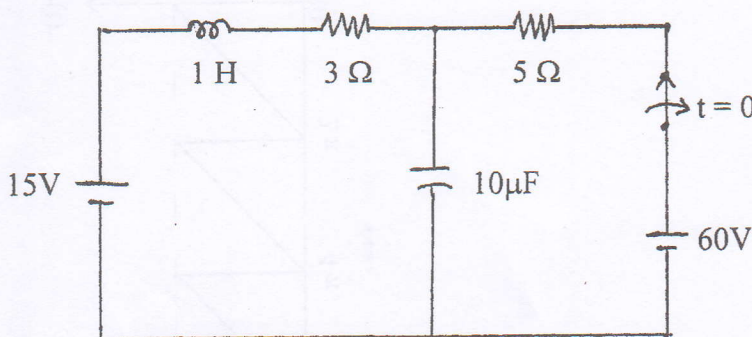

3. a) For the circuit shown in figure below, Find the current and voltage of capacitor for $t > 0$ using Laplace Transform method. [8]

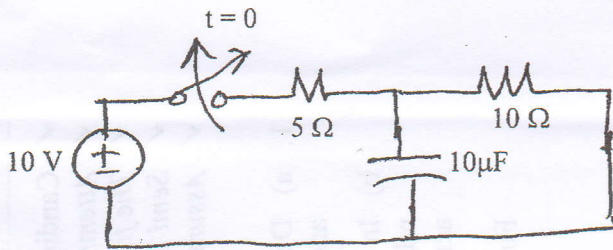

- b) After being closed for a long time, if the switch in the circuit shown in figure below is opened at $t = 0$. Obtain the expressions for $i_L(t)$ and $v_C(t)$ for $t > 0$, using Laplace Transform Method. [8]

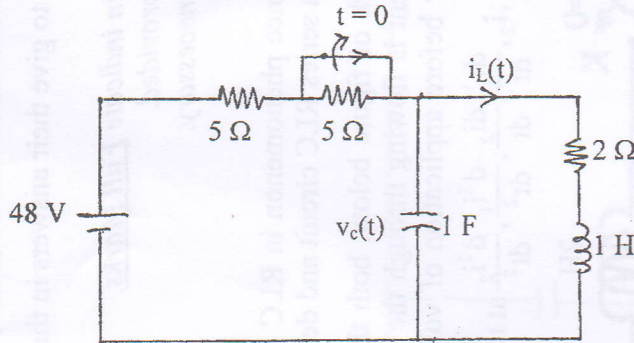

4. a) For the given two port network, determine the driving point impedance and voltage ratio transfer function. [4]

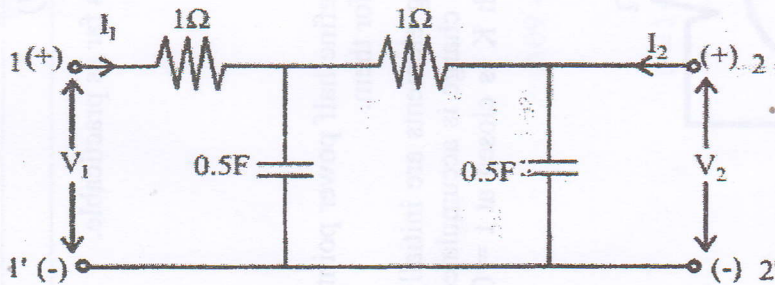

- b) Sketch the Bode Plot for the transfer function given by [8]

$$H(S) = \frac{200(S+1)}{[S(S+5)(S^2+2S+100)]}$$

- c) Show that all overall transmission parameter matrix for cascaded two 2-port networks is simply the matrix product of transmission parameters for each individual 2-port network in cascade. [4]

5. a) Find the y and g-parameters of the circuit in figure below and also find whether the network is reciprocal or not. [8]

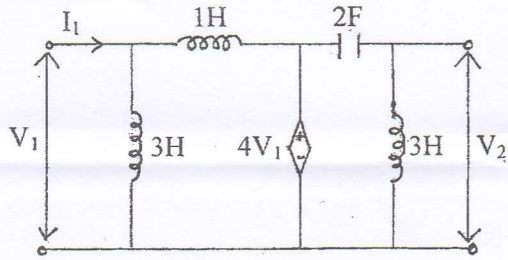

- b) Obtain trigonometric Fourier series of the waveform shown in figure below and sketch the line spectra. [8]

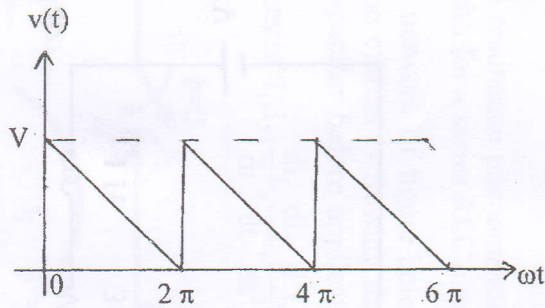

Exam.	New Batch (2066 & Later Batch)		
Level	BE	Full Marks	80
Programme	BEL, BEX, BCT	Pass Marks	32
Year / Part	II / I	Time	3 hrs.

Subject: - Electric Circuit Theory (EE501)

- ✓ Candidates are required to give their answers in their own words as far as practicable.
- ✓ Attempt All questions.
- ✓ All questions carry equal marks.
- ✓ Necessary Semi-log graph paper is Provided.
- ✓ Assume suitable data if necessary.

1. a) A voltage $u(t) = 100\sin\omega t$ is applied to a series RLC circuit. At the resonant frequency of the circuit, the maximum Voltage across the capacitor is found to be 400 V. The Bandwidth is known to be 600 rad/sec and impedance at resonance is 100Ω . Find the resonant frequency and compute the upper and lower limits of the bandwidth. Also determine the value of L and C of the circuit.
- b) In the network shown in figure below a steady state is reached with the switch open. At $t = 0$, the switch is closed. Determine the value of $u_a(0^-)$ and $u_a(0^+)$.

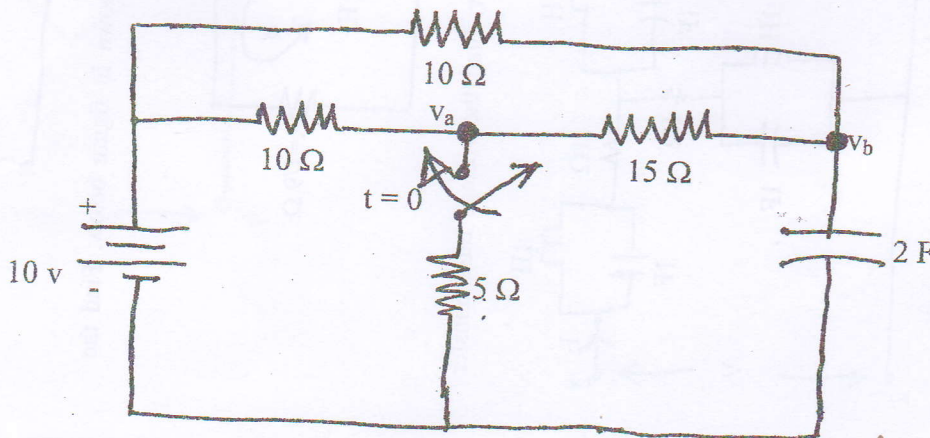

2. a) Using classical method in the circuit shown in figure below. Find the voltage across capacitor for $t > 0$.

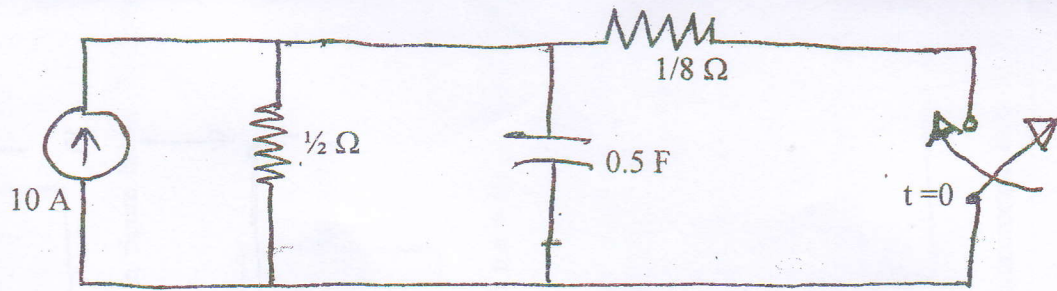

- b) Using classical method, in the circuit shown in figure below. Find the current through inductor and voltage across capacitor for $t > 0$

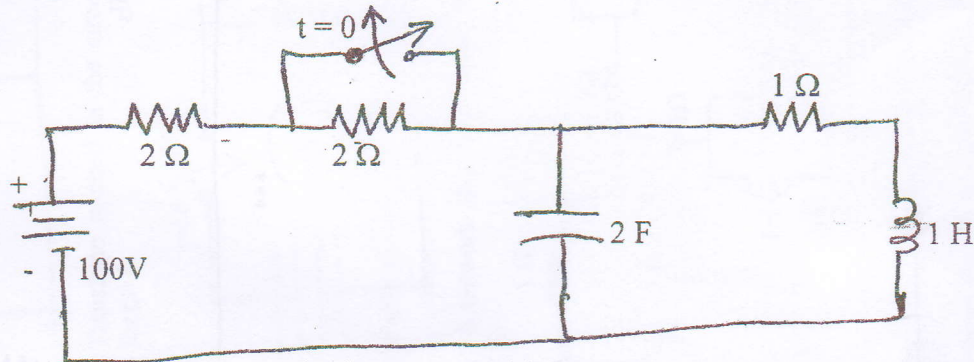

3. a) Using Laplace Transform method in the circuit shown in figure below find the voltage and current of capacitor for $t > 0$

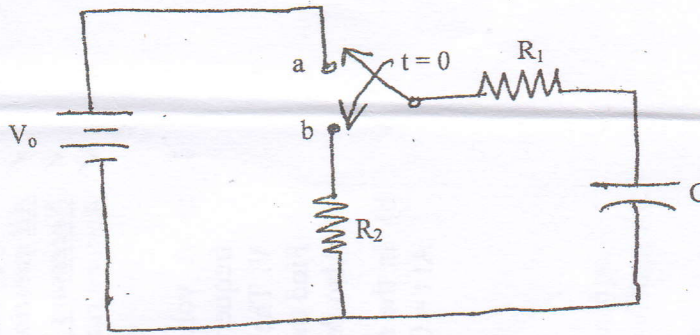

- b) Using Laplace Transform method in the circuit shown in figure below. Find the current i_1 and i_2 for $t > 0$.

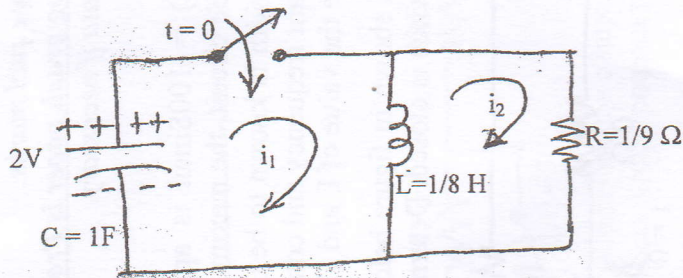

4. a) For the Two-Port network shown in figure below. Find the voltage ratio transfer function.

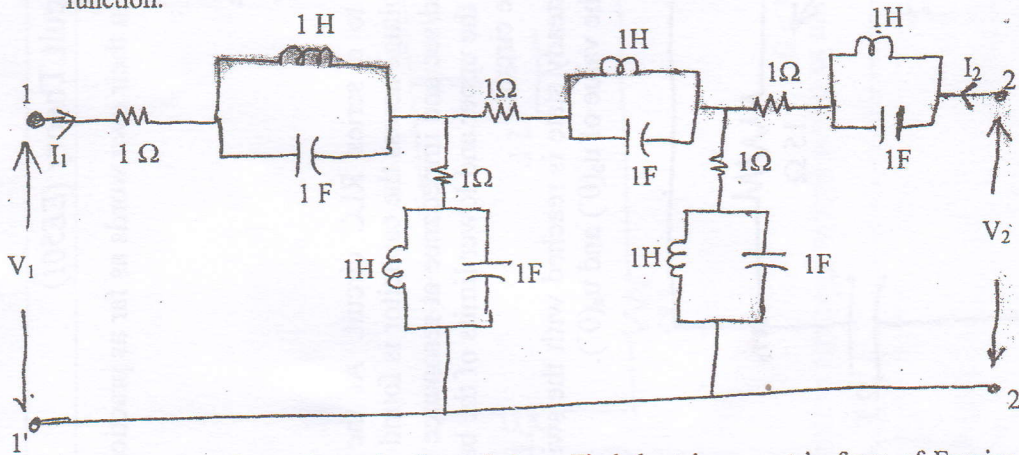

- b) For the Waveform shown in figure below. Find the trigonometric form of Fourier Series and plot the line spectrum.

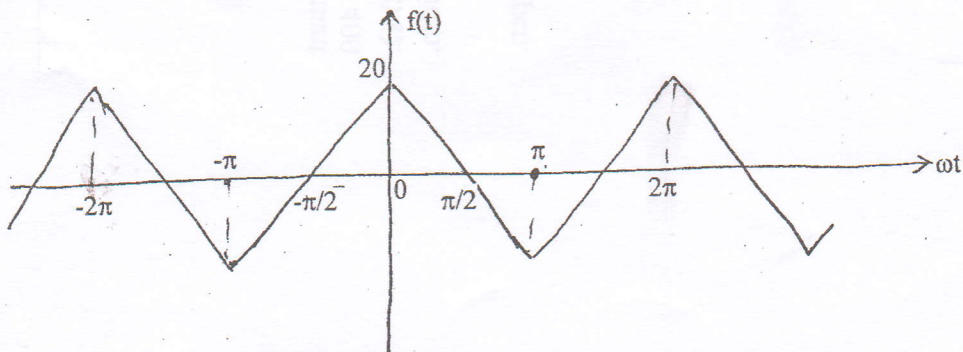

5. a) For the network function given below, plot the asymptotic Bode diagram

$$H(S) = \frac{20(s+1)}{s(s+5)(s^2+2s+10)}$$

- b) For the Two Port network shown in figure find Transmission parameter and Y-parameter.

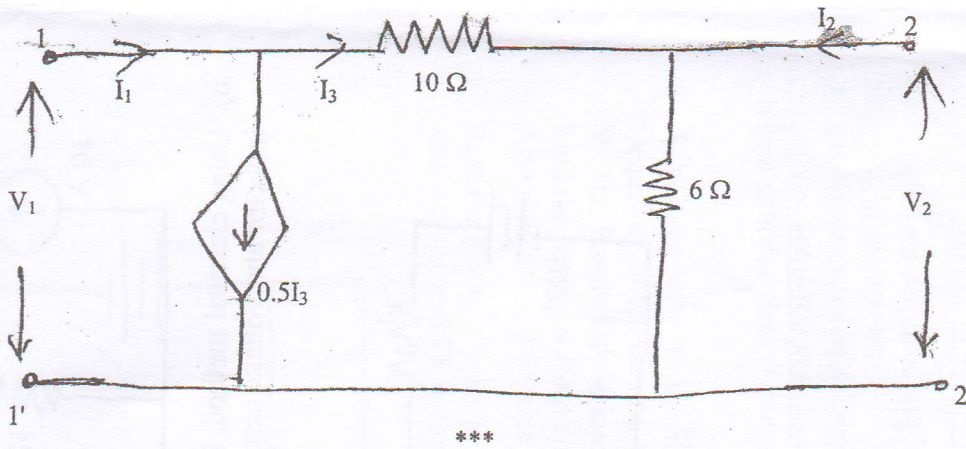

Exam.	Regular		
Level	BE	Full Marks	80
Programme	BEL, BEX, BCT	Pass Marks	32
Year / Part	II / I	Time	3 hrs.

Subject: - Electric Circuit Theory (EE501)

- ✓ Candidates are required to give their answers in their own words as far as practicable.
- ✓ Attempt All questions.
- ✓ The figures in the margin indicate Full Marks.
- ✓ Assume suitable data if necessary.

1. a) What do you understand by the bandwidth of a series resonant circuit? Explain with the help of resonance curve and also derive its expression both in terms of ω and f . [8]
- b) In the circuit shown in figure below, switch K is closed at time $t = 0$. Find the values of $i_1, i_2, di_1/dt, di_2/dt, d^2i_1/dt^2, d^2i_2/dt^2$ at $t=0+$. [8]

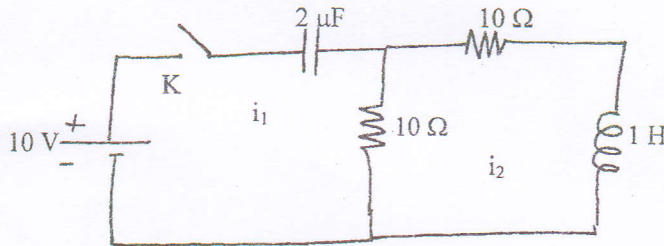

2. a) In the circuit of the figure below, the switch K is open and the circuit reaches a steady state. At $t = 0$, K is closed. Find the current in the inductor $t > 0$. Use classical method. [8]

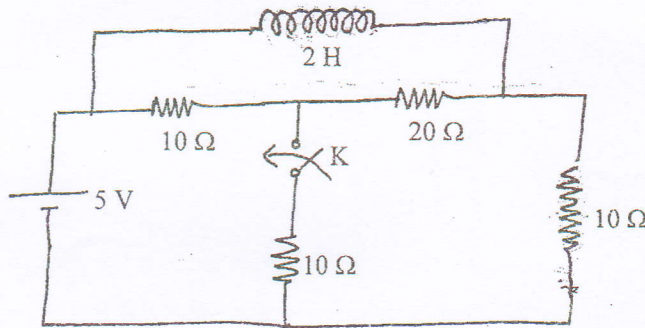

- b) In the circuit shown in figure below capacitor C has an initial voltage $V_C = 10$ volts and at the same instant, current through the inductor L is zero. The switch K is closed at $t = 0$. Find out the expression for the voltage $V(t)$ across the inductor L using classical method. [8]

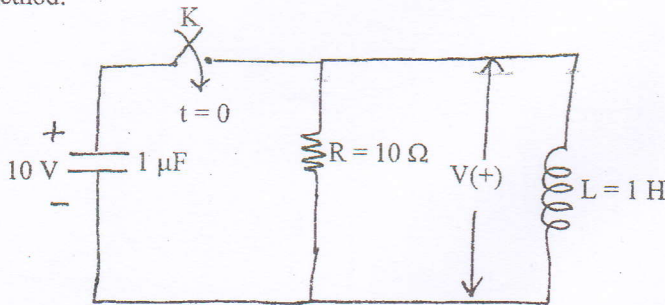

3. a) Using Laplace transform method find the expressions for $i_1(t)$ and $i_2(t)$ in the given two mesh network shown in figure below provided that the network is unenergised. [8]

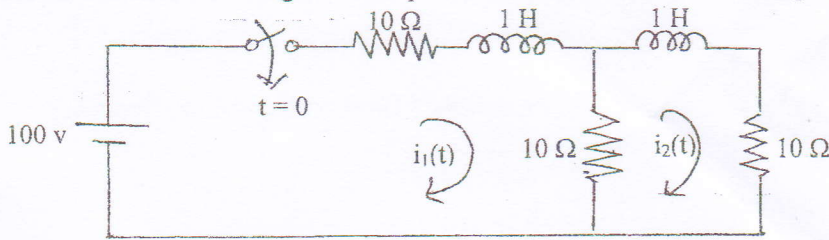

- b) Using Laplace Transform method, find the current of inductor and capacitor for $t > 0$ in the circuit shown in figure below. [8]

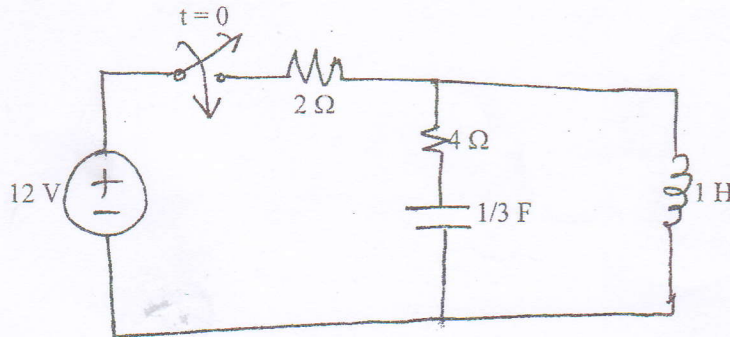

4. a) Find the trigonometric Fourier series for the waveform shown in figure below and plot the line spectrum. [8]

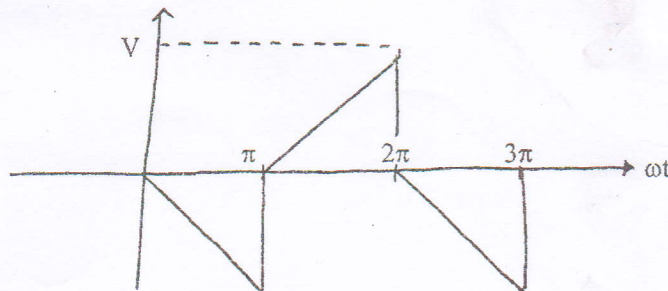

- b) For the network shown in figure below find the voltage ratio transfer function and transfer impedance. [8]

5. a) Sketch the bode plot for the transfer function given by [6]

$$G(S) = \frac{20(S+1)}{(S^2 + 4S + 2)(S^2 + 5S)}$$

- b) Find Z-parameters and hence the T-parameters for the 2 port network shown in figure below. [6]

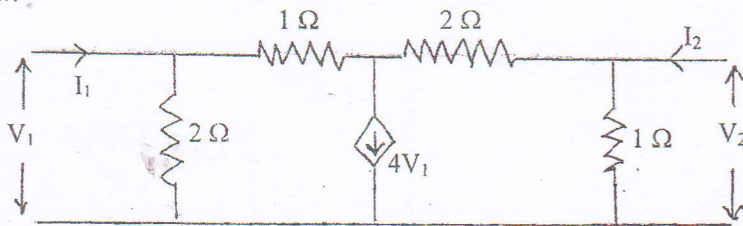

- c) What do you understand by reciprocal two-port network? Also derive the condition for the same in terms of T parameters. [4]

Exam.	Regular		
Level	BE	Full Marks	80
Programme	BEL, BEX, BCT	Pass Marks	32
Year / Part	II / I	Time	3 hrs.

Subject: - Electric Circuit Theory (EE501)

- ✓ Candidates are required to give their answers in their own words as far as practicable.
- ✓ Attempt All questions.
- ✓ The figures in the margin indicate Full Marks.
- ✓ Assume suitable data if necessary.

1. a) Explain the phenomenon of Resonance in parallel RLC circuit and derive expression for resonance frequency. [8]
- b) In the circuit shown in following figure, find the loop currents i_1, i_2, i_3 at $t = 0^+$. [8]

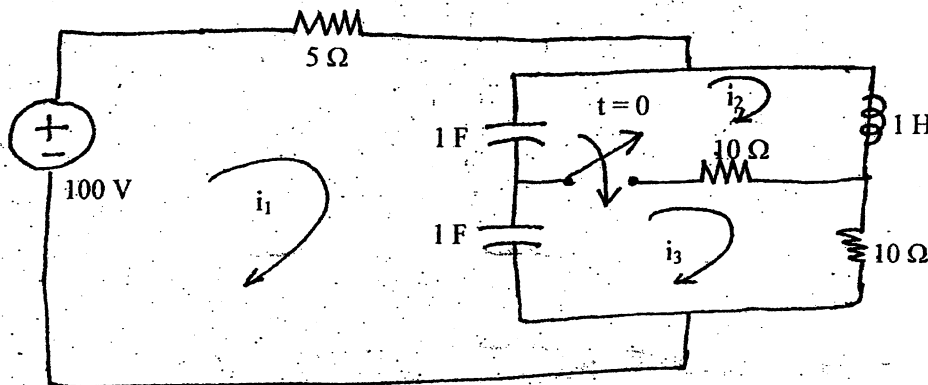

2. a) Find $v_a(t)$ for $t > 0$ in the figure below using classical method. [8]

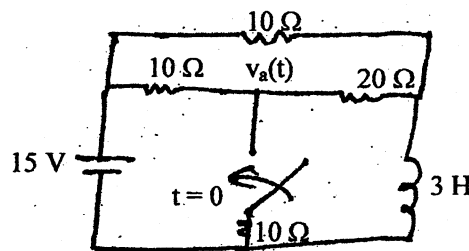

- b) Keeping the switch closed for a long time, if the switch is opened at $t = 0$ in the circuit shown in figure below, find expression for voltage across capacitor in the circuit shown in below using classical method of solution. [8]

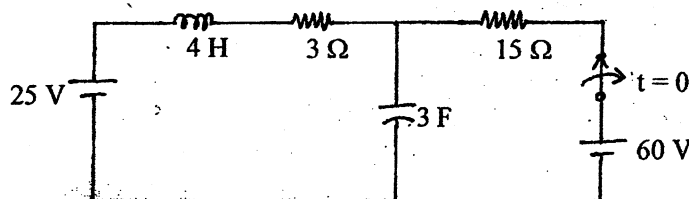

3. a) Using Laplace Transform method, find the current and voltage across inductor for $t > 0$ in the circuit shown in figure below. [8]

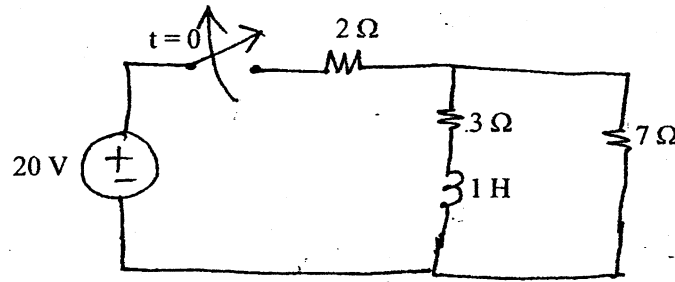

- b) Using Laplace transform method, find the loop currents i_1 and i_2 for $t > 0$ in the circuit shown in the following figure. [8]

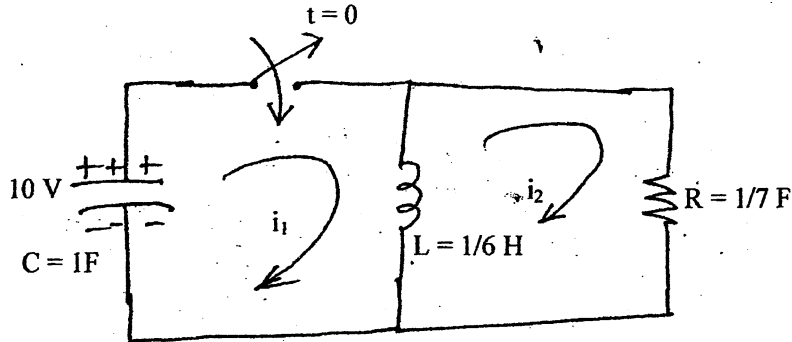

4. a) For the 2-port network shown in figure below, find voltage ratio transfer function, $G_{21}(S)$ and transfer admittance, $Z_{21}(S)$. [8]

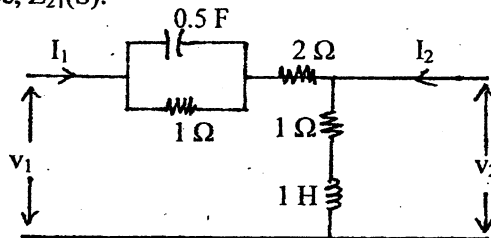

- b) Obtain trigonometric Fourier series of the waveform in figure below and sketch the line spectra. [8]

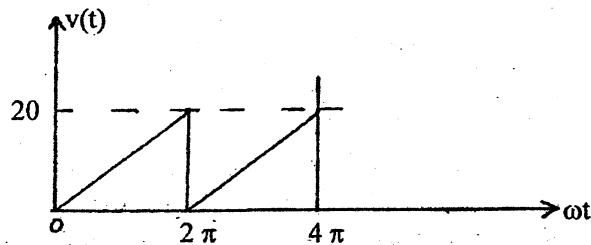

5. a) For the transfer function below, draw the asymptotic Bode plot [8]

$$G(s) = \frac{20(s+5)}{s(s+20)(s^2+80s+200)}$$

- b) The Y-parameters of two TPNS are given as: [8]

$$\begin{bmatrix} 1/4 & -5/4 \\ -1/4 & -3/4 \end{bmatrix} \text{ and } \begin{bmatrix} 1/3 & -1/3 \\ -1/3 & 1/3 \end{bmatrix}. \text{ If these two TPNS are connected in series. What will be the equivalent Transmission parameter of the combination?}$$

Exam.	Regular		
Level	BE	Full Marks	80
Programme	BEL, BEX, BCT	Pass Marks	32
Year / Part	II / I	Time	3 hrs.

Subject: - Electrical Circuit Theory (EE501)

- ✓ Candidates are required to give their answers in their own words as far as practicable.
- ✓ Attempt All questions.
- ✓ The figures in the margin indicate Full Marks.
- ✓ Semi log paper will be provided.
- ✓ Assume suitable data if necessary.

1. a) In the given circuit determine voltage across 1Ω resistor using mesh analysis method. [6]

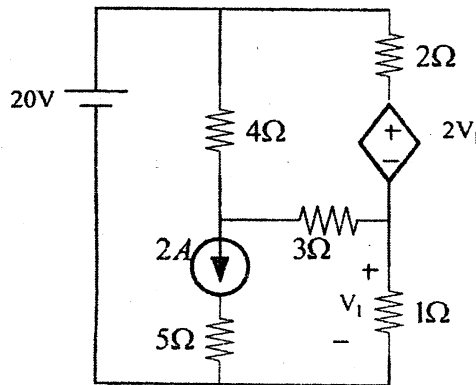

- b) Explain the phenomenon of resonance in RLC series circuit. Derive the expression for resonant frequency, bandwidth, half power frequencies and quality factor. [6]
- c) Derive an expression with necessary diagrams for resonance frequency of a circuit consisting of a coil in parallel with a capacitor excited by a sinusoidal AC voltage. [4]
2. a) In the network shown in figure below the switch is changed from a to b at $t = 0$. Show that at $t = 0^+$ $i_1 = i_2 = -\frac{V}{R_1 + R_2 + R_3}$ and $i_3 = 0$. Also find the voltage across C_1 , C_2 , C_3 , L_1 and L_2 at $t = 0^+$ [8]

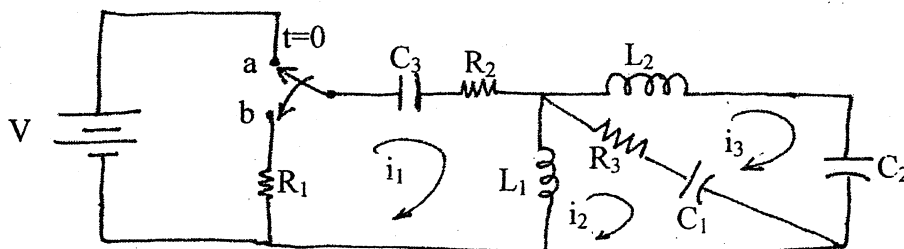

- b) Switch in the circuit is suddenly opened at $t = 0$ after steady state has been reached in the closed position of the switch. Use classical method to determine the expression for voltage across capacitor for $t > 0$. [8]

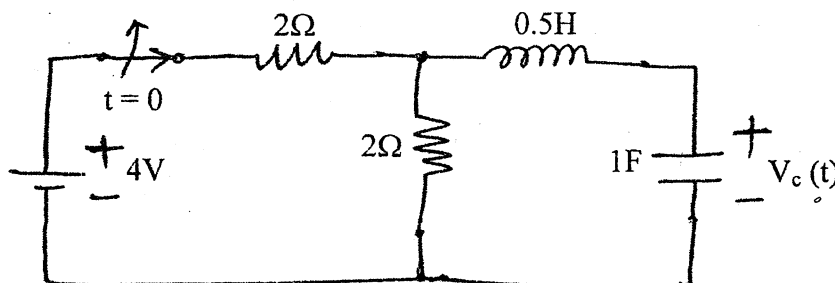

3. a) In the circuit shown switch is opened for a long time and then it is suddenly closed at $t = 0$. Obtain the expression for current through inductor for $t > 0$. Also calculate the voltage across inductor after 10mSec. [Use classical method] [8]

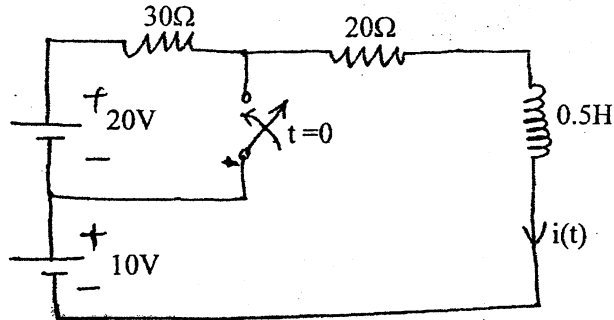

- b) Using Laplace transform method, find the current i_1 and i_2 for $t > 0$ in the circuit of figure below. [8]

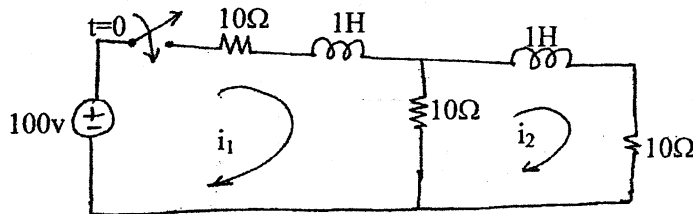

4. a) In a series RLC, as shown in figure below find the value of current for $t > 0$, also find the voltage across capacitor for $t > 0$, using Laplace transform method. [6]

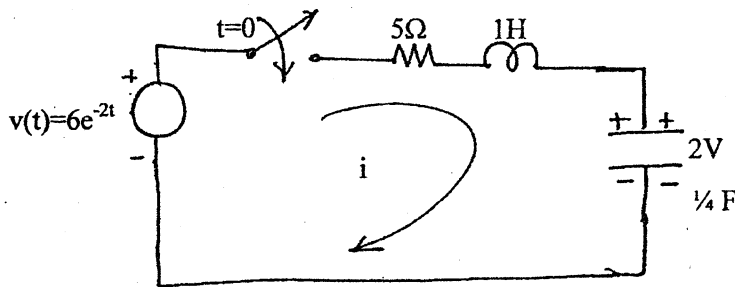

- b) With necessary circuit diagram, obtain the equivalent Y-parameter if three two-port networks are connected in parallel. [4]

- c) If the two port network, shown in figure below is terminated with a 2Ω resistor at port 2 then for this terminated network find following network function. (i) G_{21} (ii) α_{21} [6]

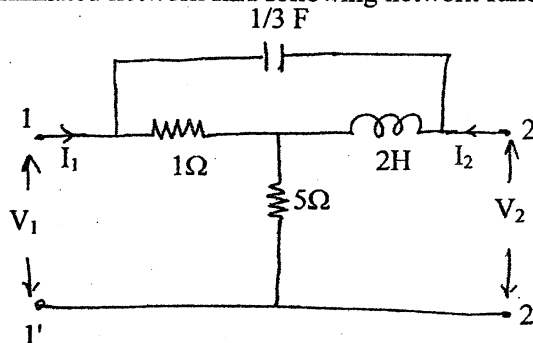

5. a) Sketch the asymptotic bode plots for the transfer function given by

$$N(S) = \frac{10(S+10)}{S(S^2 + 5S + 4)(S+40)}$$

[8]

- b) Find the trigonometric Fourier series for the given waveform shown and also sketch the line spectrum.

[8]

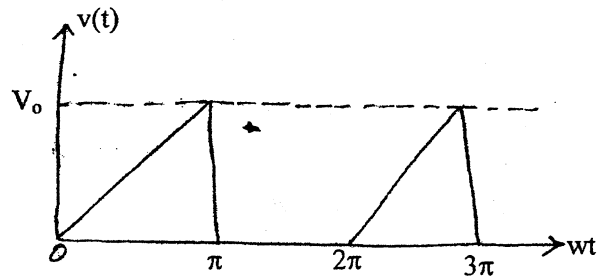

Exam.	Regular / Back		
Level	BE	Full Marks	80
Programme	BEL, BEX, BCT	Pass Marks	32
Year / Part	II / I	Time	3 hrs.

Subject: - Electric Circuit Theory

- ✓ Candidates are required to give their answers in their own words as far as practicable.
- ✓ Attempt **All** questions.
- ✓ The figures in the margin indicate **Full Marks**.
- ✓ **Semilog graph paper is attached herewith.**
- ✓ Assume suitable data if necessary.

1. a) A 50Ω resistor is connected in series with a coil having resistance R and inductance L , a capacitor "C" and 100V variable frequency supply as shown in figure below. At a frequency of 200Hz, the maximum current of 0.7Amp flows through the circuit and voltage across the capacitor is 200V. Determine the value of R , L , and C . [6]

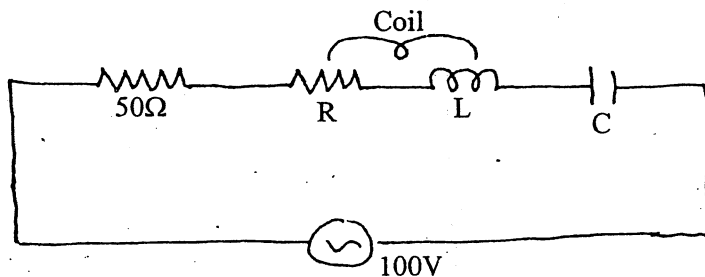

- b) Explain the phenomenon of resonance of a parallel ac circuit and hence derive the expression for the resonant frequency. [6]
2. a) The switch has been opened for a long time as shown in figure below. At time $t = 0$, it is suddenly closed. At $t = 0^+$, find current through inductor, voltage across capacitor, charge across capacitor, current and voltage across each resistor. [8]

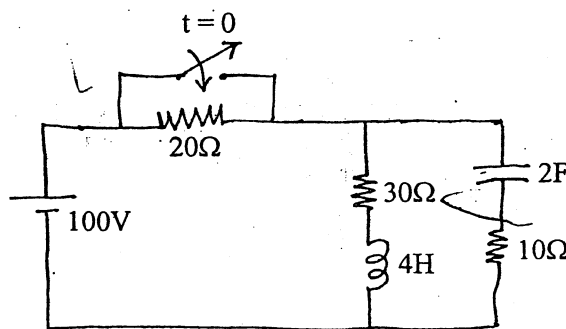

- b) At $t = 0$, switch is closed in the circuit of figure below. Find the $V_c(t)$ and $i_c(t)$ using classical method.

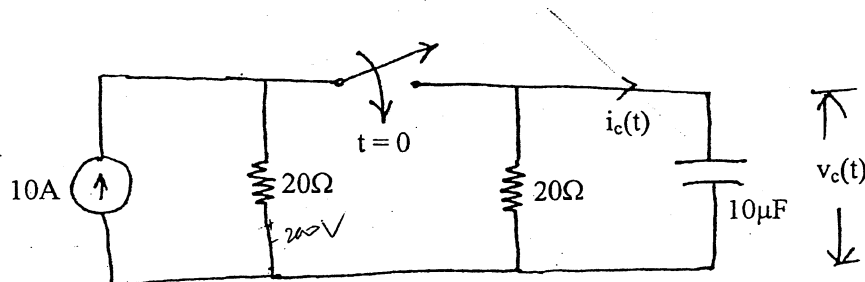

$\tau = RC = 10 \times 10^{-6} = 10^{-5}$
 $i_c(t) = 10 e^{-t/10^{-5}}$
 $V_c(t) = 200 e^{-t/10^{-5}}$

3. a) In a series R-L circuit the applied voltage is $v(t) = 10 \sin(10^4 t + \frac{\pi}{6})$ with $R = 2\Omega$, $L = 0.01\text{H}$. $v(t)$ is applied at $t = 0$. Obtain the particular solution for current $i(t)$ through the circuit. Assume zero initial current through the inductor. [Use classical method]. [8]
- b) In the network shown below, the switch is closed at $t = 0$. With the network parameter values given, find the expression for $i_1(t)$ and $i_2(t)$ using Laplace transform method. The network is energized before the switch is closed. [8]

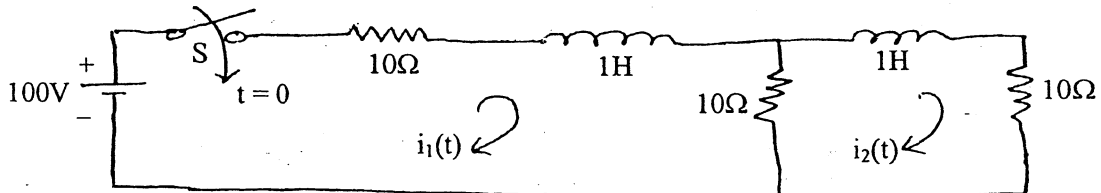

4. a) Sketch the Bode plots for the transfer function given by $N(S) = \frac{10(S+10)}{(S^2 + 40S)(S^2 + 5S + 4)}$. [8]
- b) The given figure shows a voltage waveform in the form of a train of isosceles triangles. Determine the Fourier series and plot the line spectrum. [8]

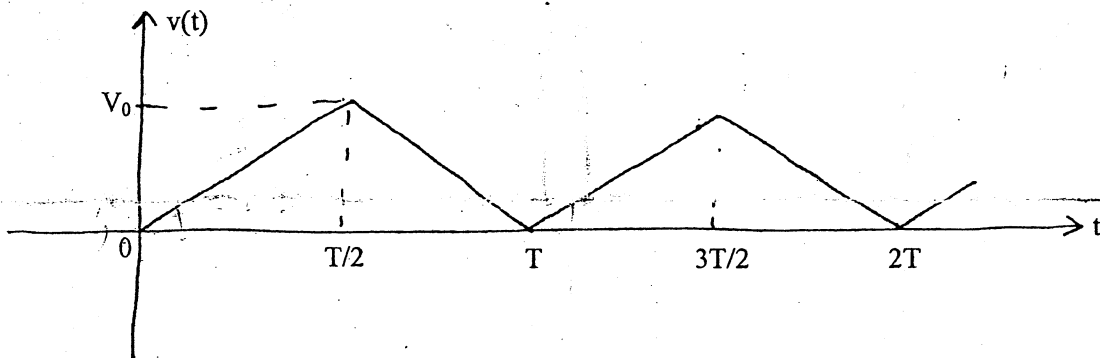

5. a) For the two port network shown below, find the driving point impedance of port one and the voltage ratio transfer function. [10]

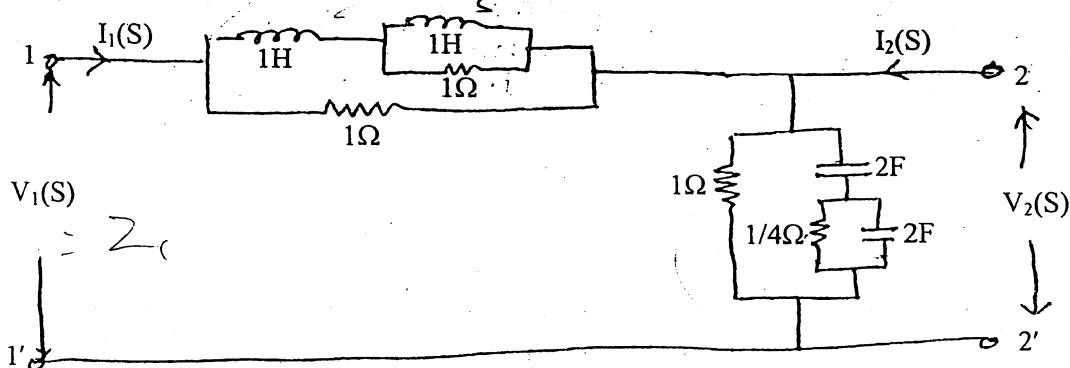

- b) What do you understand by frequency response of networks and hence highlight the role of complex frequency in studying the frequency response. [6]
- c) With necessary circuit diagram, obtain the equivalent Z -parameter if three two port networks are connected in series. [4]

Exam.	Regular		
Level	BE	Full Marks	80
Programme	BEL, BEX, BCT	Pass Marks	32
Year / Part	II / I	Time	3 hrs.

Subject: - Electric Circuit Theory (EE 501)

- ✓ Candidates are required to give their answers in their own words as far as practicable.
- ✓ Attempt any **All** questions.
- ✓ The figures in the margin indicate **Full Marks**.
- ✓ Assume suitable data if necessary.

1. a) How does resonance occur in RLC series circuit? Define half power points and bandwidth for a series RLC circuit and derive the expression for them. [8]
- b) In the parallel resonant circuit as shown in the figure below, find resonance frequency, Q factor and band width. [8]

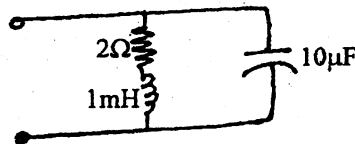

2. a) For the circuit shown in following figure, find the current i_1, i_2, i_3 at $t = 0^+$. [8]

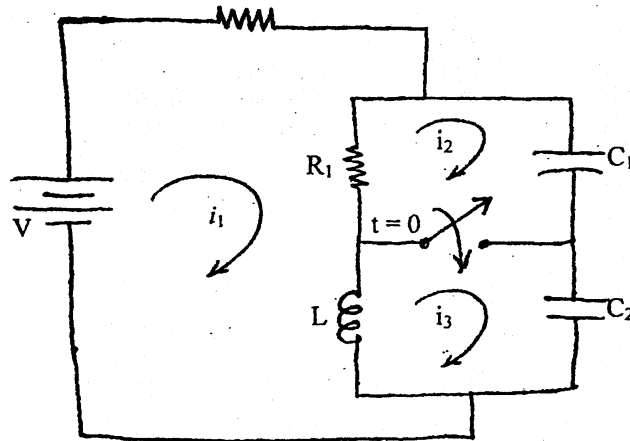

- b) For the circuit shown in following figure, use classical method to find the current in the inductor for $t > 0$. [8]

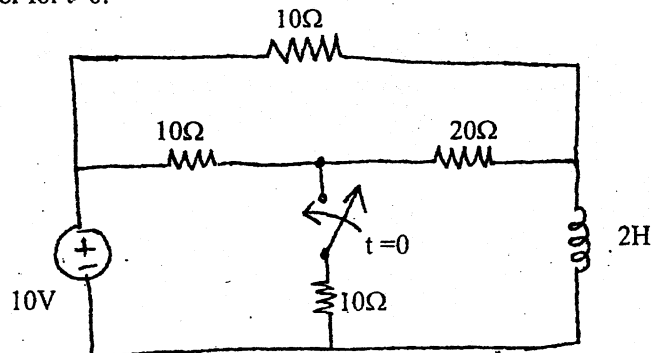

3. a) An exponential voltage $v(t) = 2e^{-4t}$ is applied at time $t = 0$ to a series R-L circuit comprising a resistor $R = 1\Omega$ and a inductor $L = 0.25H$. Obtain the particular solution for current $i(t)$ through the circuit. Assume zero initial current through the inductor. Use classical approach. [8]

- b) In the following network the switch was closed for a long time before it is being opened at $t = 0$. Find the expression for $V_C(t)$ for $t > 0$. (Use classical method). [8]

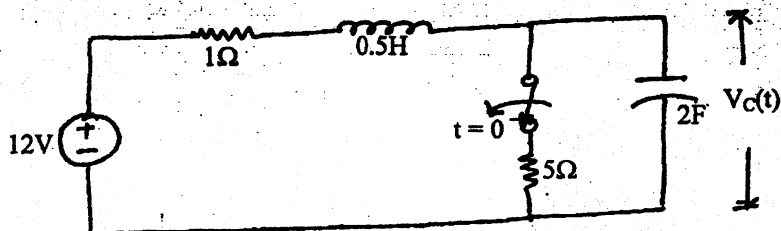

4. a) Using laplace transformation technique, find the expression for current $i(t)$ in the network shown below for $t > 0$ when the switch is closed at $t = 0$. Assume zero initial charge across the capacitors. [6]

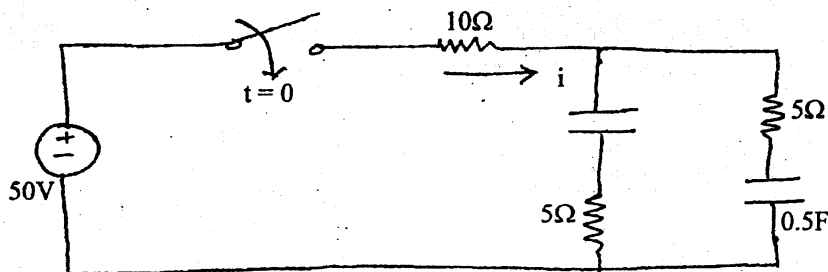

- b) What do you understand by a reciprocal two port network? Derive the condition for reciprocity in terms of y -parameters. [4]
 c) Find the Z -parameters in the network shown below and also check for its reciprocity and symmetry. [6]

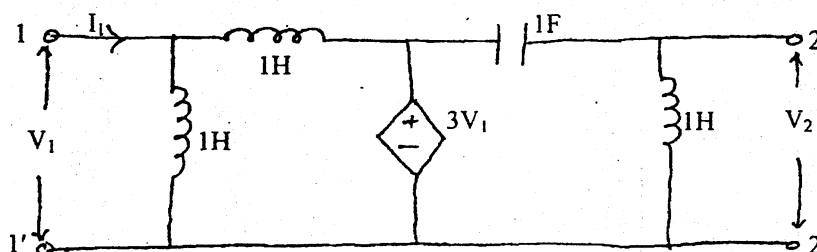

5. a) Sketch the asymptotic bode plots for the transfer function given by:

$$N(S) = \frac{2s^2(S+5)}{(S^2 + 22S + 40)(S+10)} \quad [8]$$

- b) The following figure shows a voltage waveform in the form of a train of isosceles triangles. Determine the Fourier series and plot the line spectrum. [8]

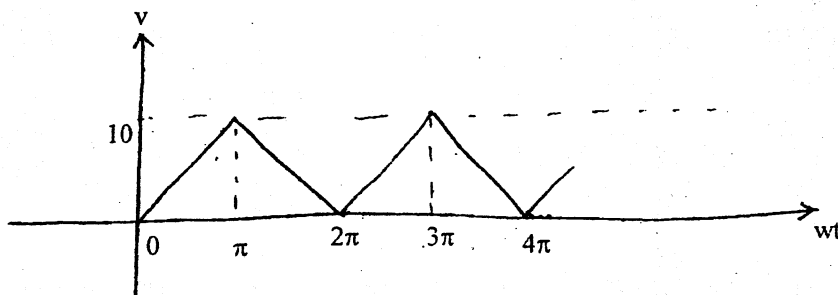

Exam.	New Back (2066 Batch)		
Level	BE	Full Marks	80
Programme	BEL, BEX, BCT	Pass Marks	32
Year / Part	II / I	Time	3 hrs.

Subject: - Electric Circuit Theory

- ✓ Candidates are required to give their answers in their own words as far as practicable.
- ✓ Attempt any Five questions.
- ✓ The figures in the margin indicate Full Marks.
- ✓ Semilog graph paper will be provided.
- ✓ Assume suitable data if necessary.

1. a) Define half power points and bandwidth for a series RLC circuit and derive the expression for them. How is the bandwidth affected by quality factor of the circuit? [8]
- b) The switch has been open for a long long time in the circuit shown below and at $t = 0$ it is suddenly closed. Find i_L , v_C , q_C , i_2 , i_3 , i_1 , i_C , v_L , v_3 , v_1 , v_2 at $t = 0^+$. [8]

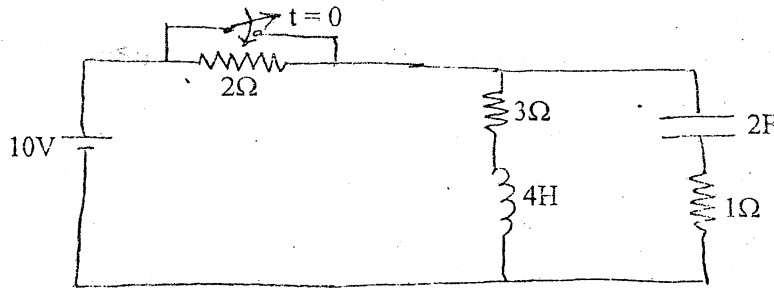

2. a) In the two mesh network shown in the figure below, the switch is closed at $t = 0$. Find the mesh currents $i_1(t)$ and $i_2(t)$ as shown, and the capacitor voltage $v_C(t)$. [Use classical approach]. [8]

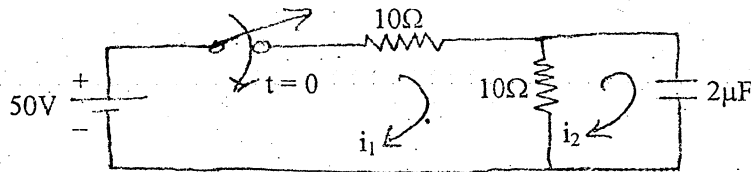

- b) An exponential voltage $v(t) = 20e^{-4t}$ is suddenly applied at time $t = 0$ to a series RC circuit with $R = 1\Omega$, $C = 0.25F$. Obtain the particular solution $i(t)$ in the circuit. Assume zero initial charge across capacitor. [Use classical method.] [8]
3. a) In the given circuit below, switch S_1 is closed at $t = 0$ and after 8ms, the switch S_2 is opened. Find the complete expression for current in the interval $0 < t < 8ms$ and $t > 8ms$. Use Laplace Transform approach. [8]

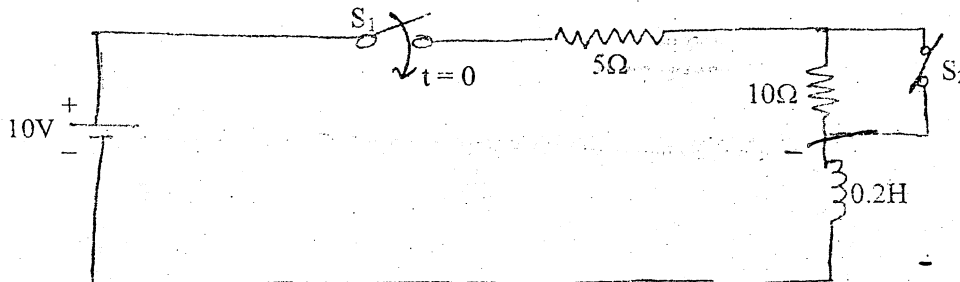

- b) The circuit shown below is in steady state with switch 'S' closed. The switch is opened at $t = 0$. Using Laplace Transform method, find $i_L(t)$ in the circuit. [8]

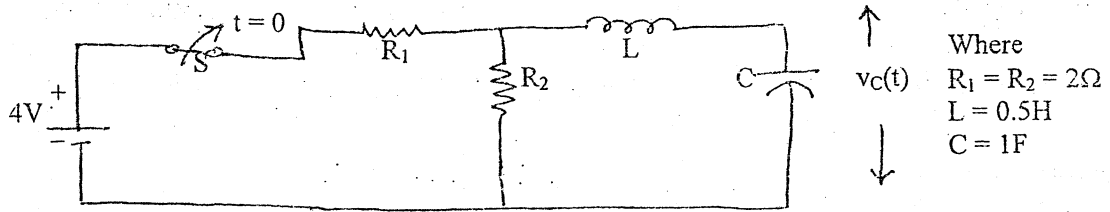

4. a) For the given 2-port network shown in figure below, find the voltage ratio transfer function. [8]

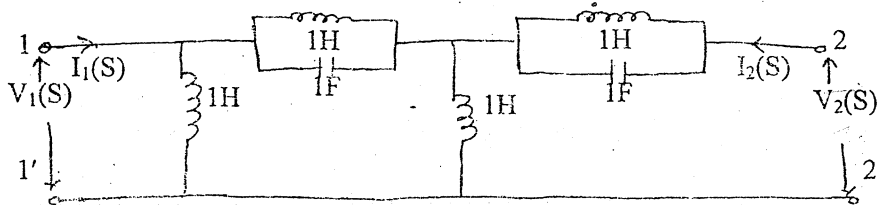

- b) What do you understand by poles and zeros of a network function? State their significance in analyzing the time domain response of a network. [4]
 c) Determine the equivalent Y-parameter if two port Networks are connected in parallel. [4]
 5. a) Obtain the T and Y parameters of the given 2-port network shown in following figure. Also check for the symmetry and/or reciprocity of the network. [8]

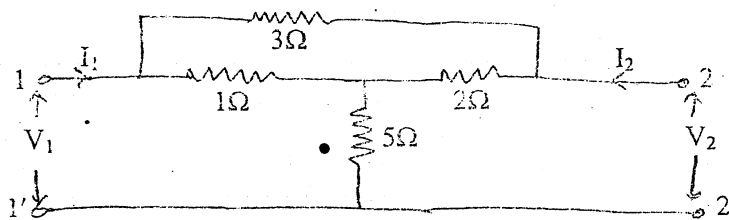

- b) Sketch the asymptotic Bode plots for the transfer function given by [8]

$$G(S) = \frac{20(S+5)}{S(S^2 + 2S + 10)(S^2 + 21S + 20)}$$

6. a) For the network shown below, find the Z and g parameters and show that the network is neither reciprocal nor symmetrical. [8]

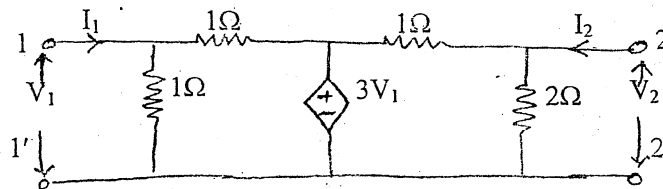

- b) The network of figure shown below has an applied voltage of $v(t) = (40 \sin \omega t + 80 \sin 3\omega t)$ volts where $\omega = 500$ rad/s. Find the current response and hence the average power. [8]

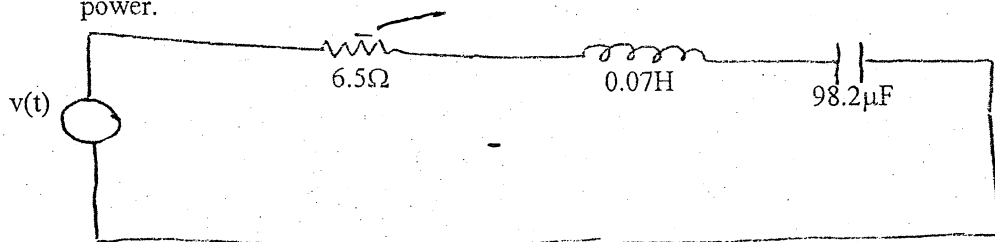

Exam.	Regular/Back		
	Level	BE	Full Marks
Programme	BEL, BEX, BCT	Pass Marks	32
Year / Part	II / I	Time	3 hrs.

Subject: - Electric Circuits II

- ✓ Candidates are required to give their answers in their own words as far as practicable.
- ✓ Attempt any Five questions.
- ✓ The figures in the margin indicate Full Marks.
- ✓ Semilog graph paper will be provided.
- ✓ Assume suitable data if necessary.

1. a) Using mesh analysis, determine the value of V_s so that the current through 3Ω resistor is 6.76 Amp as shown in the following figure. [8]

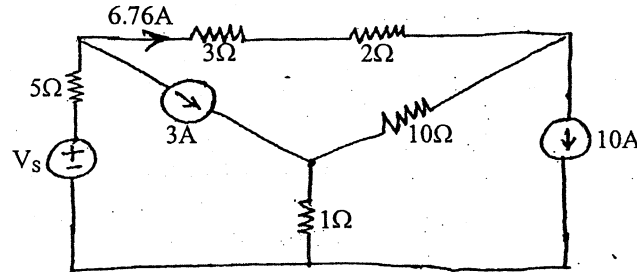

- b) Mention the importance of initial conditions in the circuit analysis. Draw the equivalent circuit showing the initial and final condition for inductor and capacitor. [4]

- c) In the given circuit, switch K is closed at time $t = 0$. Find $i_1(0^+)$, $i_2(0^+)$, $\frac{di_1(0^+)}{dt}$ and $\frac{di_2(0^+)}{dt}$. [4]

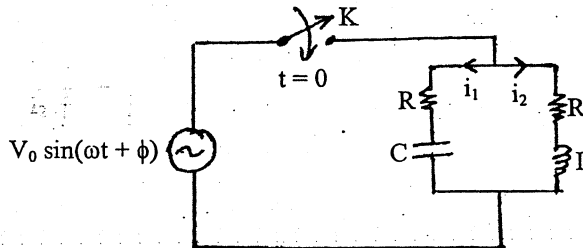

2. a) In the given circuit, after the switch has been in the open position for a long time, it is closed at $t = 0$. Find the voltage across the capacitor using classical method. [8]

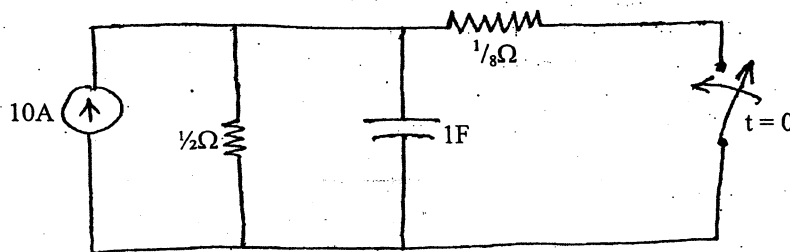

- b) In the network shown, the switch is closed at $t = 0$. Find the current supplied by the source using Laplace transform method. [8]

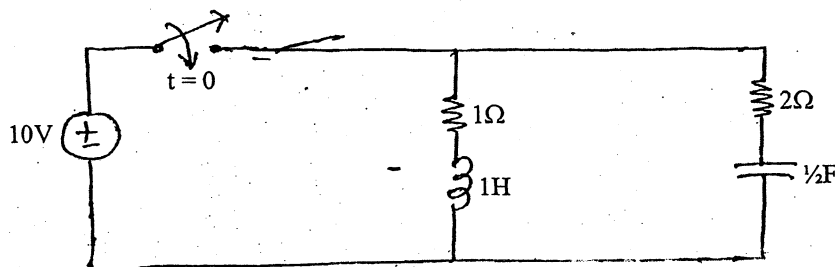

3. a) With the switch S in position 1, the circuit shown below attains equilibrium. At time $t = 0$, the switch is moved to position 2. Find the voltage across $5M\Omega$ resistor. (Use Laplace transform method) [8]

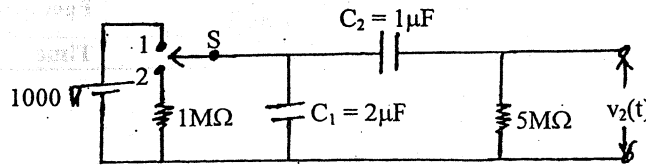

- b) In the circuit shown below, switch S_1 is closed at $t = 0$ and S_2 is opened at $t = 4$ msec. Determine $i(t)$ for $t > 0$. Assume that inductor is initially de-energized. (Use Laplace method) [8]

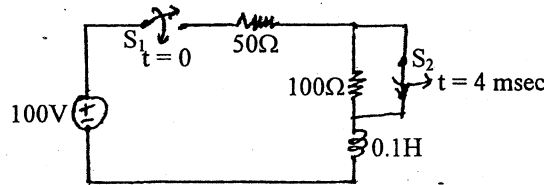

4. a) Find the exponential form of Fourier series for the given Saw-tooth wave. [8]

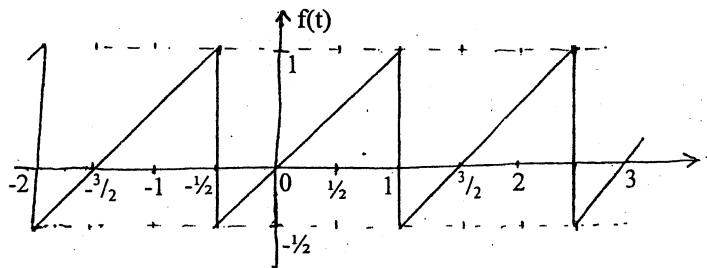

- b) Find the current ratio and voltage ratio transfer function for the network given. [8]

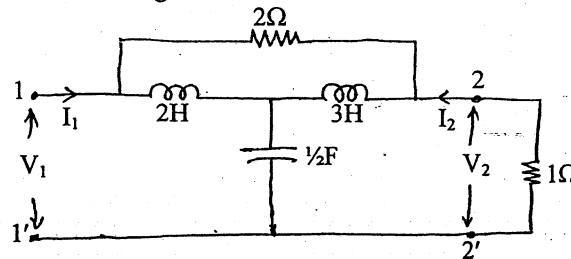

5. a) Sketch Bode-plot for the transfer function given by $G(S) = 10 \frac{S(S+3)}{(S+1)(S^2+2S+16)}$. [8]

- b) With a suitable example prove that the forced response of a network depends upon the nature of input excitation while the natural response never depends upon the input excitation. [8]

6. a) Find the transmission and y-parameter of the two port network given in the following figure and also prove that the network is neither reciprocal nor symmetrical. [8]

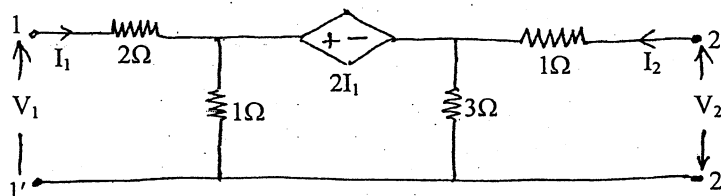

- b) Write the state variable formulation of the circuit shown. [8]

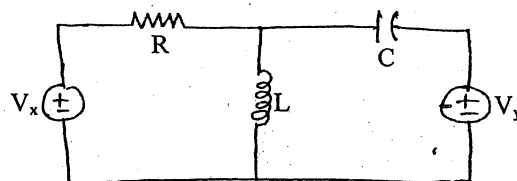

Exam.	Old Back (2065 & Earlier Batch)		
Level	BE	Full Marks	80
Programme	BEL, BEX, BCT	Pass Marks	32
Year / Part	II / I	Time	3 hrs.

Subject: - Electric Circuit II (EG527EE)

- ✓ Candidates are required to give their answers in their own words as far as practicable.
- ✓ Attempt any **Five** questions.
- ✓ The figures in the margin indicate **Full Marks**.
- ✓ Assume suitable data if necessary.

1. a) Find the current in each branch of the figure using nodal analysis. [8]

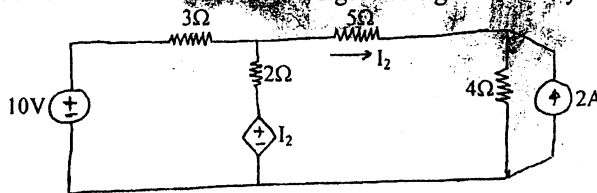

- b) In the network shown in figure below, a steady state is reached with switch open. At $t = 0$, the switch is closed. Determine the value of $V_a(0^-)$ and $V_a(0^+)$. [8]

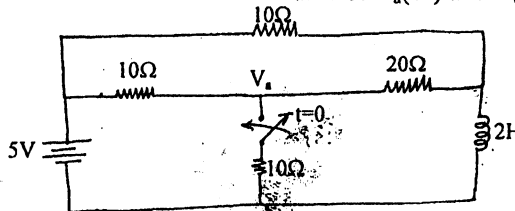

2. a) Using classical method, find the expression for the current supplied by the source in the network shown in figure. Also find the time taken by the source current to reach 25mA? [8]

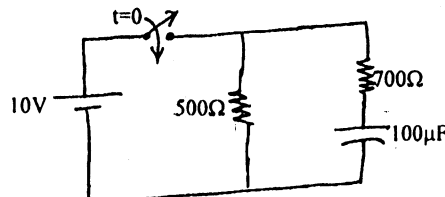

- b) Using Laplace transform method, find the current $i(t)$ for $t > 0$ in the circuit shown in the figure below. [8]

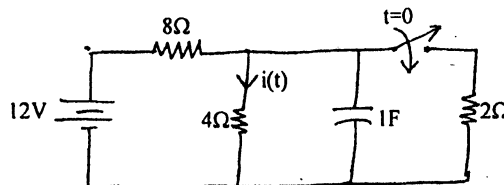

3. a) Using classical method find the expression for current through the inductor for $t > 0$ in the circuit shown in figure. [8]

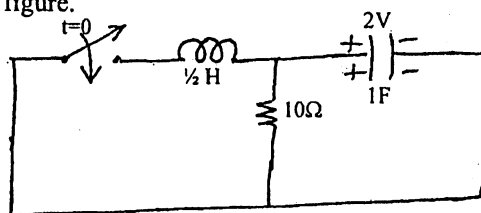

- b) Using Laplace transform method, find the expression for current through 2Ω resistor for $t > 0$ in the circuit shown in figure. [8]

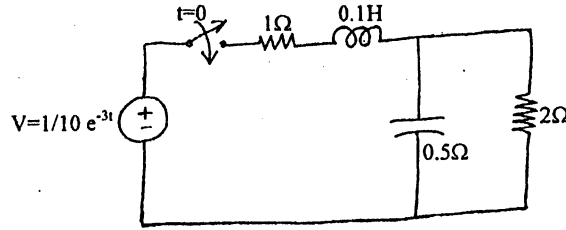

4. a) For the two-port network, find the current ratio transfer function as well as voltage ratio transfer function. [8]

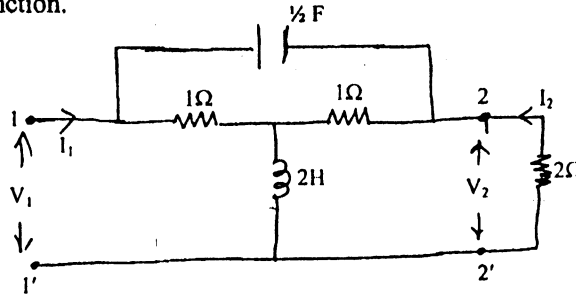

- b) Find the trigonometric Fourier series for the waveform shown and also sketch the line spectrum. [8]

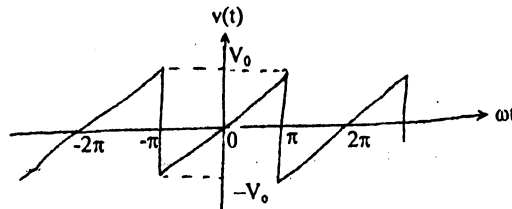

5. a) Sketch the asymptotic Bode-plot for the transfer function given by: [10]

$$T(s) = \frac{10(s+10)}{s(s^2 + 5s + 4)(s + 40)}$$

- b) Express transmission line parameters in terms of Y-parameter. [6]

6. a) Find the Z-parameter and T-parameter for the two-port network given in the following figure. [8]

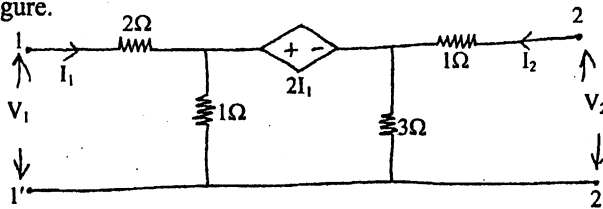

- b) Obtain the state model of the network shown in following figure. [8]

